

PLAN

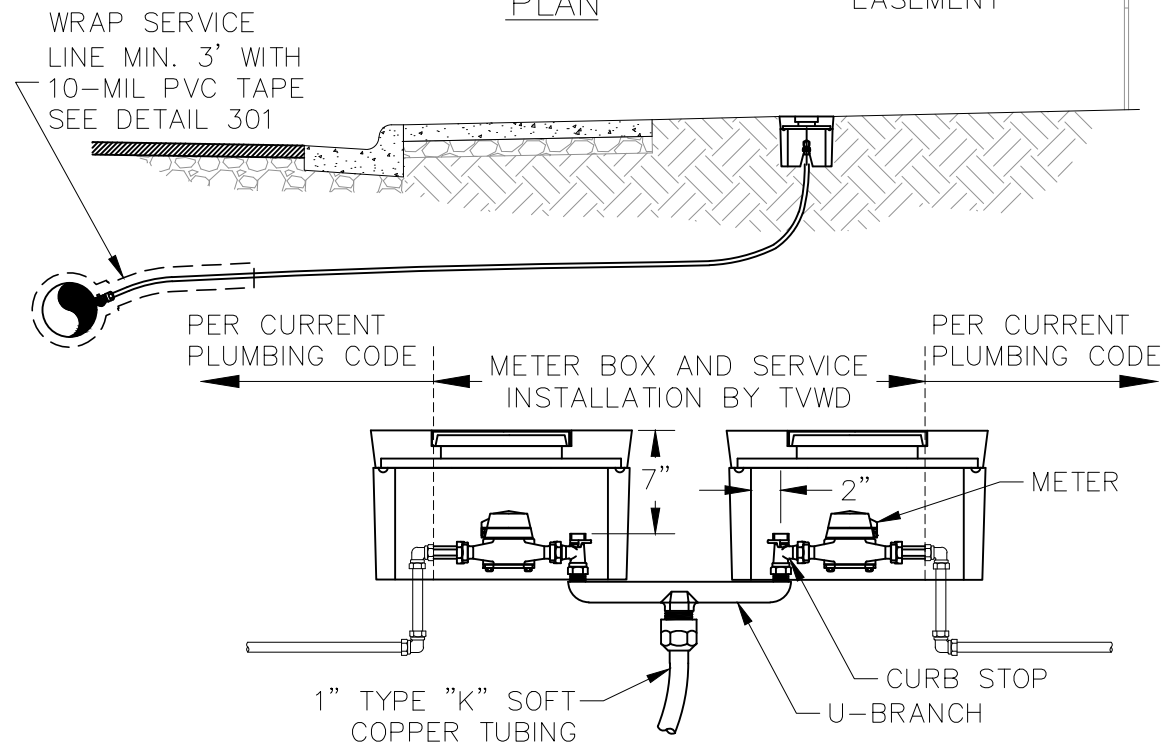

ELEVATION

NOTES:

1. DEVELOPER'S SURVEYOR SHALL SET A LATH AT THE INTERSECTION OF THE PROPERTY LINE AND THE PUBLIC UTILITY EASEMENT. DEVELOPER'S SURVEYOR SHALL ALSO MARK THE PROPERTY LINE AND LOT NUMBERS ON THE FACE OF CURB WITH WHITE PAINT.
2. IF PROPERTY CORNER MONUMENTS HAVE NOT BEEN SET AT THE TIME OF WATER SERVICE INSTALLATION, THE DEVELOPER'S SURVEYOR SHALL SET A LATH AT THE PROPERTY CORNER LOCATION ON THE RIGHT-OF-WAY LINE.
3. ORS 92.044(7) PROHIBITS LOCATING ANY UTILITY INFRASTRUCTURE WITHIN 1 FOOT OF A SURVEY MONUMENT. DEVELOPER SHALL PAY FOR ANY RELOCATION OF SERVICES AND/OR METER BOXES FOUND TO FALL WITHIN 1 FOOT OF A SURVEY MONUMENT LOCATION.
4. SEE SECTION 8.2 OF THE STANDARDS FOR BACKFLOW REQUIREMENTS.



TUALATIN VALLEY
WATER DISTRICT

DESIGNED: MBA

APPROVED: NWA

SCALE: NONE

**DUAL WATER SERVICE
TYPICAL INSTALLATION
WITH CURBTIGHT
SIDEWALK**

DATE: 9/2020

DETAIL

602