

Willamette Water Supply System Commission

Board Meeting
Thursday, June 2, 2022
12:00 PM

Microsoft Teams Meeting

Willamette Water Supply System Commission
Board Meeting Agenda
Thursday, June 2, 2022 | 12:00 – 1:30 PM
Microsoft Teams Meeting

If you wish to attend via conference call and need dial-in information, please contact annette.rehms@tvwd.org or call 971-222-5957 by 10:00 a.m. on June 2, 2022. If you wish to address the WWSS Board, please request the Public Comment Form and return it 48 hours prior to the day of the meeting. **All testimony is electronically recorded.**

REGULAR SESSION – 12:00 PM

CALL TO ORDER

1. GENERAL MANAGER'S REPORT – Dave Kraska

Brief presentation on current activities relative to the WWSS Commission

2. PUBLIC COMMENT

This time is set aside for persons wishing to address the Board on items on the Consent Agenda, as well as matters not on the agenda. Additional public comment will be invited on agenda items as they are presented. Each person is limited to five minutes unless an extension is granted by the Board. Should three or more people testify on the same topic, each person will be limited to three minutes.

3. CONSENT AGENDA

These items are considered to be routine and may be approved in one motion without separate discussion. Any Board member may request that an item be removed by motion for discussion and separate action. Any items requested to be removed from the Consent Agenda for separate discussion will be considered immediately after the Board has approved those items which do not require discussion.

- A. Approve the May 5, 2022 meeting minutes
- B. Adopt FY22-23 WWSS Board Meeting Schedule

4. BUSINESS AGENDA

- A. Approve RWF_1.0 GMP 1.5 for Construction – *Mike Britch*
- B. Approve WWSP Program and Construction Management Services FY 2023 Annual Work Plan – *Dave Kraska*

5. INFORMATION ITEMS

- A. Planned July Business Agenda items – *Joelle Bennett*
- B. The next Board Meeting is scheduled on July 7, 2022, via Microsoft Teams

6. COMMUNICATIONS AND NON-AGENDA ITEMS

- A. None scheduled

ADJOURNMENT

Willamette Water Supply System Commission

(this page intentionally left blank)

GENERAL MANAGER'S REPORT

To: WWSS Board of Commissioners
From: David Kraska, P.E., WWSS General Manager
Date: June 2, 2022
Subject: Willamette Water Supply System General Manager's Report

This report provides an overview of some of the current Willamette Water Supply System (WWSS) work efforts under the direction of this Commission, beginning with a Safety Minute presentation.

- 1. Permitting and Communications Updates** – The Willamette Water Supply Program (WWSP) permitting efforts remain very active. Attached to this General Manager's Report is a tabulation of the permits and approvals recently granted, and the status of those currently in process.

Permitting highlights:

- For the Metzger Pipeline East (MPE)_1.2 project, WWSP received the Clean Water Services Site Development permit and the Portland & Western Railroad Right of Entry/Crossing permit.
- Washington County issued conditional land use approval for the MPE_1.3 staging area and Right of Way access permits.
- Tualatin Valley Fire and Rescue issued blasting permits for PLM_4.3 and PLM_5.3.

Communications highlights:

- The Communications Team provided information to Pamplin Media as they prepared the article *What's Next with the Willamette Water Pipeline Construction*, which ran on May 26, 2022. The article provided an overview of the Willamette Water Supply Program and included a map of the system. It highlighted the improvements made to the Willamette River Water Treatment Plant (Raw Water Facility) in Wilsonville and the road closures along Southwest Scholls Ferry Road and Hall Boulevard for the Metzger Pipeline East project. Pamplin Media called the attention to the WWSP's regional partnerships and coordination of the Program's crossing of Highway 217 with the Oregon Department of Transportation's projects in the same area.
- Neighboring property owners, emergency response organizations, and Washington County Land Use and Transportation were notified of the first test and production blasts at the Water Storage Tank (RES_1.0) site which occurred on Friday, May 13.

- 2. Construction Status Updates** – Attached to this General Manager's Report is a tabulation of construction project status. A few highlights include:

- Began installation of 66-inch waterline on PLM_5.3.
- Continued rock excavation at the RES_1.0 site.
- Completed tunnel bore under railroad tracks on Scholls Ferry Road for MPE_1.2 48-inch waterline.
- Began drilling for rock blasting at WTP_1.0 site.

- 3. Steel Market Exposure Update** – The price of hot rolled band, the material used to fabricate WWSS transmission pipe, continues to fluctuate in 2022. Pricing has decreased approximately five percent since late April 2022. Current pricing is approximately 15 percent less than the fifteen-month average, 33 percent below the peak. With the receipt of the final pipeline project bid, the Program's exposure to steel pricing volatility is limited. Program staff are working with our construction contractors to mitigate possible delays to our construction projects from long lead times. Staff are continuing to monitor the steel market and are not recommending a change in construction procurement plans and strategies at this time.

Willamette Water Supply Program Permits and Approvals – Recent Actions and Status

Date of Report: May 19, 2022

Permits and Approvals Recently Granted

Agency	Projects Involved	Permit or Approval Granted
Clean Water Services	MPE_1.2	Site Development permit (requirement for WaCo grading permit)
Portland & Western Railroad	MPE_1.2	Right of Entry/Crossing permits
Genesee Wyoming Railroad	PLM_1.3	Fully executed Contractor Right of Entry permit
DEQ	PLM_4.3	1200-C
TVF&R	PLM_5.3 & WTP_1.0	Blasting permits
DSL	RWF_1.0	Permit Modification 6 (Air Burst Pipe Repair)
ODFW	System-Wide	Fish Salvage permit renewal
WCLUT	MPE_1.3	Conditional land use approval, staging area
WCLUT	MPE_1.3 & PLM_4.3	ROW Utility permit
WCLUT	RES_1.0	Retaining Wall permits
Hillsboro	PLW_1.2	Erosion Control permit

Permits and Approvals Submitted

Agency	Projects Involved	Permit or Approval Submitted
DEQ	PLM_1.3	1200-C comments addressed and resubmitted
WCLUT	RES_1.0	East Valve and Flow Meter Vault Building permits
Sherwood	PLM_4.3	Compliance Agreement (for grading and erosion control permit)
Hillsboro	PLW_2.1	Land Use applications for Orenco Woods Nature Park

Permits and Approvals in Progress

Agency	Projects Involved	Permit or Approval in Progress
Wilsonville	PLM_1.3	Landscape plans modifications
WCLUT	RES_1.0	Building permits (remaining 5 of 7)

Anticipated Approvals

Agency	Projects Involved	Permit or Approval Anticipated
WCLUT	MPE_1.2	ROW Access permit and Grading permit
Beaverton	MPE_1.2	Site development permit amendment, PFC facility; Building permit, PFC facility
Sherwood	PLM_4.3	Grading and Erosion Control permit; Engineering permit
TriMet	PLW_2.1	ROW license

Willamette Water Supply Program Projects Construction – Recent Status Update

Date of Report: May 19, 2022

Project	Description	Progress Since Last Month
1. RWF_1.0	Raw Water Facilities project located at the Willamette River Water Treatment Plant	<ul style="list-style-type: none"> - Completed Phase 1 as-built documents - Engineer conforming drawing set for upcoming Phase 2 work - Continuing administrative close-out work on GMP#1 - Planning and preparation for upcoming summer work package GMP#1.5 - Preparing for upcoming GMP#2
2. WTP_1.0	Water Treatment Plant project, located in City of Sherwood, near the intersection of SW Tualatin-Sherwood Road and SW 124 th Avenue	<ul style="list-style-type: none"> - Mobilization of temporary trailers to site - Topsoil stripping and stockpiling - Haul-off of unsuitable soils - Stockpiling of rock/boulders - Temporary fence - Drilling for test blast of rock
3. PLM_4.1	Finished water pipeline project being completed in partnership with Washington County's Highway 99 Crossing Pipeline and Tualatin Sherwood Road – Langer Farms Parkway to Borchers Drive	<ul style="list-style-type: none"> - Utility and storm drain piping - Road widening on Roy Rogers Rd. west of Hwy 99 - Road widening on Tualatin-Sherwood Road - WWSP submittals and RFIs
4. PLM_4.4	Finished water pipeline project being completed in partnership with Washington County's Chicken Creek to Borchers Dr	<ul style="list-style-type: none"> - WWSP submittals and RFIs
5. PLW_1.2	Finished water pipeline project in South Hillsboro from TV HWY to Frances Street	<ul style="list-style-type: none"> - Road widening on west side of Cornelius Pass Road - Overhead and underground utility relocations - WWSP submittals and RFIs
6. PLW_1.3	Finished water pipeline project in South Hillsboro from SW Farmington Road to SE Blanton Street	<ul style="list-style-type: none"> - CAV and blowoff appurtenances - Pressure testing
7. MPE_1.1/ COB_1.1	Finished water pipeline project being completed in partnership with the City of Beaverton's SW Western Avenue project	<ul style="list-style-type: none"> - Completed 48" WWSP waterline between Allen and RR tracks on Western Ave. (1st phase of work) - Total of 2100 LF of 48" waterline installed (55%) - Began 16" COB waterline on Allen Blvd
8. MPE_1.2/ COB_1.2	Finished water pipeline project in Beaverton from SW Scholls Ferry Road at Greenway to SW Allen Boulevard at Western Avenue	<ul style="list-style-type: none"> - Began tunnel beneath railroad tracks on Scholls Ferry Road for 48" WWSP pipeline - Began shaft construction for tunnel at lower Fanno Creek - Continued 16" COB open cut waterline on Cascade Ave - Continued 48" open cut waterline (night work) on Scholls Ferry Road between Hwy 217 and Hall Blvd
9. RES_1.0/ PLM_5.3	Water Storage Tank and finished water pipeline project in rural Washington County. Tank site at SW Grabhorn Road and Stonecreek Drive. Pipeline extends from SW Grabhorn Road at SW Tile Flat Road Clark Hill to SW Rosedale Road at future Cornelius Pass Extension.	<ul style="list-style-type: none"> - Continued earthwork at reservoir and staging area #1 sites - Temporary haul road construction for PLM_5.3

Willamette Water Supply
Our Reliable Water

Safety Minute: Grilling Safety

June 2, 2022

1

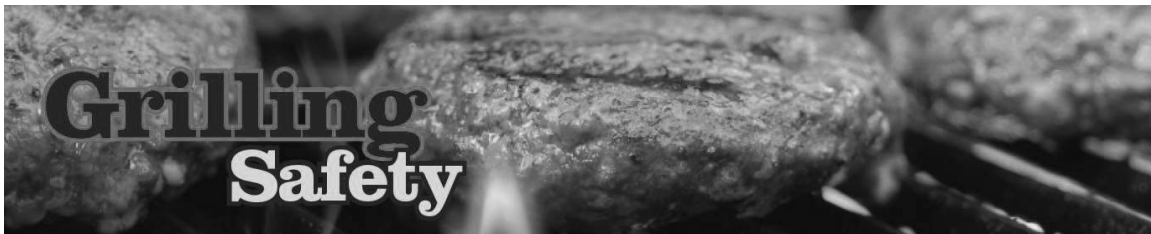

What would summer be without GRILLING?

Grilling can be an enjoyable experience, but it can also be quite dangerous if not done in a safe manner.

Here are some grilling dos and don'ts:

Willamette Water Supply
Our Reliable Water

2

2

Grilling Safety Dos

1. Keep the grill a minimum of 10 feet away from any structure when in use.
2. Locate the grill on a flat, level surface and make sure it can't be knocked over.
3. Clean the grill regularly.
4. Examine the grill and propane tank before use. Check for any abrasions, cuts or loose connections in the gas hose lines.
5. Keep a spray bottle on hand to control minor flare-ups.
6. Keep a fire extinguisher within a couple steps of your grill.



Willamette Water Supply
Our Reliable Water

3

Grilling Safety Don'ts

1. DON'T turn on the gas while the grill lid is closed.
2. DON'T leave grill unattended while in use.
3. DON'T overload your grill with food.
 - a) Fat that drips on the flames can cause large flare-ups.
4. DON'T use a grill indoors.
 - a) Grills release carbon monoxide that needs to be vented outside.

<https://www.firstalert.ca/community/safety-corner/grilling-safety-tips/>
<https://abcnews.go.com/Business/ten-tips-safe-summer-barbecues-learn-dos-donts/story?id=13918382>



Willamette Water Supply
Our Reliable Water

4

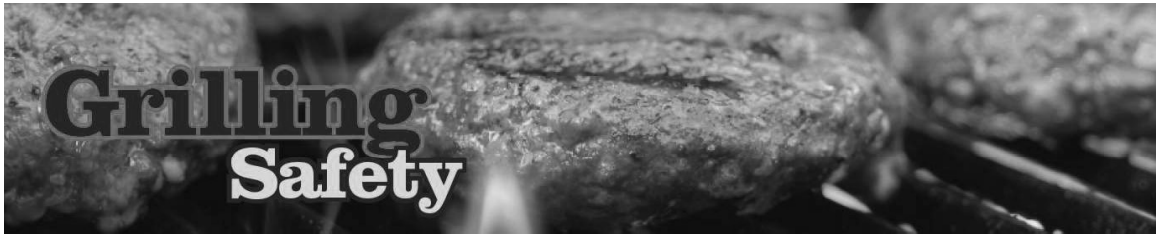

Enjoy a safe summer
barbecuing season



Willamette Water Supply
Our Reliable Water

Willamette Water Supply System Commission

(this page intentionally left blank)

**DRAFT Willamette Water Supply System Commission
Board Meeting Minutes
Thursday, May 5, 2022**

Attendance:

Commissioners present:

City of Beaverton	Marc San Soucie
City of Hillsboro	David Judah
Tualatin Valley Water District (TVWD)	Jim Duggan

Committee Members present:

City of Beaverton	Chad Lynn, David Winship
City of Hillsboro	Niki Iverson, Lee Lindsey, Eric Hielema
TVWD	Paul Matthews (<i>alternate for Tom Hickmann</i>)

Managing Agency Staff present:

WWSS Commission General Manager / Willamette Water Supply Program (WWSP) Director	Dave Kraska
TVWD General Counsel	Clark Balfour
WWSP Assistant Director	Joelle Bennett
WWSP Program Manager	Jeremy Taylor
WWSP Engineering and Construction Manager	Mike Britch
WWSP Permitting and Outreach Manager	Christina Walter
WWSP Finance Manager	Toby LaFrance
WWSS Commission Recorder / WWSP Executive Assistant	Annette Rehms

Other Attendees present:

City of Hillsboro JWC Water Treatment Manager	Chris Wilson
TVWD Asset Management Division Manager	Matt Oglesby
TVWD Water Resources Division Manager	Joel Cary
TVWD Engineering Division Manager	Nick Augustus

REGULAR SESSION – 12:00 PM

CALL TO ORDER

Chair Judah called the regular Willamette Water Supply System (WWSS) Commission meeting to order at 12:02 p.m.

ROLL CALL

Ms. Rehms administered the roll call and noted attendance.

1. GENERAL MANAGER'S REPORT

Mr. Kraska presented a safety minute on golf injury prevention (*presentation on file*).

The General Manager’s report included status updates on Willamette Water Supply Program (WWSP) permitting and communications activities; construction progress; steel market exposure; the quarterly financial report for the period ending March 31, 2022; and notice that today’s Board meeting minutes will be posted on May 16.

2. PUBLIC COMMENT

There were no public comments.

3. CONSENT AGENDA

- A. Approve the April 7, 2022, meeting minutes

Motion was made by San Soucie seconded by Duggan to approve the Consent Agenda as presented. The motion passed unanimously with San Soucie, Duggan, and Judah voting in favor.

4. BUSINESS AGENDA

- A. Adopt Sherwood Emergency Intertie IGA – *Dave Kraska*

Mr. Kraska provided an overview of the Intergovernmental Agreement between the Willamette Water Supply System Commission and the City of Sherwood. This Intergovernmental Agreement (IGA) approves the construction and future operation of an emergency intertie, for which operational details will be memorialized in a separate, but required, operations plan. The intertie will be capable of conveying up to 5 million gallons per day of water from WTP_1.0 into Sherwood’s water system and vice versa. Establishing such a connection promotes the cost-effective provision of safe and reliable water services to present and future customers. The proposed IGA defines that operating the intertie to access supplemental water supply will occur only when the requesting party is experiencing an emergency. The providing party will have full control in determining how much supply it is able to provide, dependent upon the current situation and demands. *(presentation on file)*

Commissioner Duggan reminded the Commission of the long-standing history TVWD has had with the City of Sherwood on several joint ventures. He said this IGA is a great opportunity to continue the partnership and improve the reliability of regional water systems.

In response to question, staff said the water produced by the City of Sherwood and the WWSS Water Treatment Plant are both chlorinated sources. Currently TVWD does have a supply source that is chloraminated, but that source will be phased out once WWSS is online. Staff added that in the case of an emergency the waters on either side of this intertie are very similar, because the source water treatment plants both draw from the Willamette and have nearly identical treatment processes. In terms of the taste of the water, there may be some people that can detect the difference. For the 2026 addition of WWSS water to the region’s supply portfolio, the WWSS partners must educate the customers in advance of the change and this work is included in the WWSP’s Water Supply Integration project’s efforts.

Motion was made by San Soucie, seconded by Duggan, to approve Resolution WWSS-04-22 approving an Intergovernmental Agreement between Willamette Water Supply System Commission and City of Sherwood for System Interconnection to provide long-term capability for emergency or supplemental water supply

between the two systems. The motion passed unanimously with San Soucie, Duggan, and Judah voting in favor.

B. Approve MPE_1.3 Contract for Construction – *Mike Britch*

Mr. Britch provided an overview of the MPE_1.3 Pipeline project. He reviewed the low-bid construction procurement process, the bid results, and budget information indicating the proposed contract is approximately \$8.9M above the Baseline 7.0 budget. He said the budget variance will require additional funding of \$8.9M from TVWD, as sole owner of this ancillary project. He then requested the Board's approval of Contract 2022-055 with Emery & Sons Construction Group, LLC. (*presentation on file*)

Motion was made by Duggan, seconded by San Soucie, to approve Contract 2022-055 for \$49,215,771 with Emery & Sons Construction Group, LLC for MPE_1.3 Pipeline Construction for the Willamette Water Supply Program. The motion passed unanimously with San Soucie, Duggan, and Judah voting in favor.

5. INFORMATION ITEMS

A. Planned June Business Agenda Items – *Joelle Bennett*

Ms. Bennett presented information on business agenda items planned for the June 2, 2022, WWSS Commission Regular Board meeting.

Staff anticipates recommending approval of:

1. RWF_1.0 Guaranteed Maximum Price 1.5 for Construction
2. WWSP Program and Construction Management Services Fiscal Year 2023 Annual Work Plan

B. Discussion of Fiscal Year 2022-23 Board Meeting Dates and Meeting Location – *Dave Kraska*

Mr. Kraska presented the staff report seeking direction on potentially refining the WWSS Commission Board meeting schedule for the FY2022-23 Board meetings and meeting location. Now that the program has completed design and all projects are either complete or in construction, there are fewer actions that require Board approval. Staff recommend reducing meeting frequency to every-other month meetings, on even-numbered months, beginning in October 2022. He then asked Commissioners for feedback on meeting location. He said, for the past two years, the Board Commissioners has been meeting online, using tools like Microsoft Teams, to reduce the spread of COVID-19. Meetings have been successful using the online meeting tools, but with masking and social distancing restrictions lifted across the state, there may be a desire to return to in-person meetings or a hybrid approach.

Commissioners expressed support to switch to bi-monthly meetings beginning in October and to continue meeting remotely using Microsoft Teams with the possibility of meeting in person a few times per year. Staff will review Commissioner comments and provide a proposal for approval at the June Board meeting.

C. The next Board meeting is scheduled on June 2, 2022, via Microsoft Teams.

6. COMMUNICATIONS AND NON-AGENDA ITEMS

A. None scheduled.

ADJOURNMENT

There being no further business, Chair Judah adjourned the meeting at 12:57 p.m.

David Judah, Chair

James Duggan, Vice Chair

STAFF REPORT

To: WWSS Board of Commissioners
From: David Kraska, P.E., WWSS General Manager
Date: June 2, 2022
Subject: Fiscal Year 2022-23 Board Meeting Dates and Meeting Location

Requested Board Action:

Consider adopting a resolution establishing regular meeting dates and location for the Willamette Water Supply System (WWSS) Commission Board of Commissioners for fiscal year 2022-23.

Key Concepts:

This action will provide specific dates for monthly meetings of the WWSS Commission Board to conduct business (per WWSS Intergovernmental Agreement (IGA) Article 5.2).

Background:

Meeting Frequency

To conduct regular business for the WWSS Commission, the Board of Commissioners needs to set regular business meeting dates. The IGA requires at least quarterly meetings per year and up until this point, we have held monthly meetings during the design of the WWSS. Now that the Willamette Water Supply Program (WWSP) has completed design and all projects are either complete or in construction, there are fewer anticipated actions that will require Board approval.

To be respectful of Commissioners' schedules, staff recommend reducing meeting frequency to every-other month meetings, on even-numbered months, beginning in October 2022. To allow for flexibility, placeholder appointments will be scheduled for the odd-numbered months, and additional meetings may be added to the official calendar if needed.

Meeting Location

For the past two years, the Board of Commissioners has been meeting online, using tools like Microsoft Teams, to reduce the spread of COVID-19. Staff recommend that meetings continue using online meeting tools. When the Tualatin Valley Water District Board Room can reliably accommodate hybrid meetings, staff will notify the Board and request further direction.

Budget Impact:

There are no budgetary impacts from this action.

Staff Contact Information:

Dave Kraska, P.E., WWSS General Manager, 503-941-4561, david.kraska@tvwd.org

Attachments:

- Resolution WWSS-06-2022

Willamette Water Supply System Commission

(this page intentionally left blank)

RESOLUTION NO. WWSS-06-22

A RESOLUTION ESTABLISHING REGULAR MONTHLY MEETING DATES OF THE WILLAMETTE WATER SUPPLY SYSTEM BOARD OF COMMISSIONERS FOR FISCAL YEAR 2022-23.

WHEREAS, Article 5.2 of the Willamette Water Supply System Intergovernmental Agreement requires the Board of Commissioners to generally meet monthly, but in no event less than quarterly; and,

WHEREAS, the Board of Commissioners wishes to set its regular meeting calendar by resolution, and being advised,

NOW, THEREFORE, BE IT RESOLVED BY THE BOARD OF COMMISSIONERS OF THE WILLAMETTE WATER SUPPLY SYSTEM COMMISSION:

Section 1: The regular meetings of the Commission shall be held on the following dates:

July 7, 2022
 August 4, 2022
 September 1, 2022
 October 6, 2022
 December 1, 2022
 February 2, 2023
 April 6, 2023
 June 1, 2023

Section 2: Regular meeting dates may be changed by a motion of the Board. Special meetings may be called by the Chair or by any two Commission members.

Section 3: The regular or special meetings shall be held virtually unless otherwise noticed. Meetings will start at 12:00pm.

Section 4: All Commission meetings will be advertised as required and conducted in accordance with the Oregon Public Meetings law, ORS 192.610 to 192.710.

Approved and adopted at a regular meeting held on the 2nd day of June 2022.

David Judah, Chair

James Duggan, Vice Chair

Willamette Water Supply System Commission

(this page intentionally left blank)

STAFF REPORT

To: WWSS Board of Commissioners
From: Mike Britch, P.E., WWSP Engineering & Construction Manager
Date: June 2, 2022
Subject: Approval of GMP No. 1.5 Summer Work with Kiewit Infrastructure West, Co. for RWF_1.0 Facilities Construction for the Willamette Water Supply Program

Requested Board Action:

Consider approving a change to contract 2018-013 for \$3,012,640 with Kiewit Infrastructure West, Co. to incorporate Guaranteed Maximum Price (GMP) No. 1.5 for construction of the RWF_1.0 Facilities Construction of the Willamette Water Supply Program.

Key Concepts:

- The Kiewit contract for construction manager/general contractor (CM/GC) services was executed on June 19, 2018 and was planned to be amended to include separate GMPs for Phase 1 and Phase 2 of construction.
- Phase 1 of construction began in June of 2020 and was completed in March of 2022.
- The scope included in GMP No. 1.5 includes work planned to be performed as part of Phase 2 and some in-water work, drainage improvements, and landscaping that was not completed in Phase 1. Phase 2 GMP work is not scheduled to begin until September of 2022. Authorization of GMP No. 1.5 would allow construction to be performed during the summer peak construction period and provides other benefits including:
 - Reduction of GMP 2 schedule risks
 - Saves approximately \$330K in construction escalation and stormwater prevention plan costs
 - Enables schedule flexibility for weather-dependent work
 - Completes the City of Wilsonville requirements to open the pathway to the lower overlook
- The proposed GMP No. 1.5 was developed using a combination of competitive, open-book processes, negotiated CM/GC self-performed work, and includes CM/GC contingency and Owner's contingency.
- The process for developing a Phase 2 GMP began in March of 2022 and is planned to be presented to the WWSS Board of Commissioners in September of 2022.

Background:

The RWF_1.0 project is an expansion of the existing raw water facilities at the Willamette River Water Treatment Plant (WRWTP) in Wilsonville, Oregon. The initial capacity is 60 million gallons per day. Major project scope elements include:

- Relocation of existing vertical turbine pumps (complete)
- Seismic improvements (complete)
- A section of raw water pipeline leading to the Willamette Water Supply System (WWSS) treatment plant (complete)

- Raw water pipeline crossing at Arrowhead Creek (complete)
- New vertical turbine pumps and motors with variable frequency drives
- Electrical switchgear and power distribution facilities
- Hydraulic surge tank system
- Standby power generators and fuel storage

Kiewit was selected, through a competitive, best value selection process in mid-2018, to provide the WWSP CM/GC services for the RWF_1.0 Project which included design phase, construction phase, and post-construction services.

Phase 1 construction was completed in March 2022 on time and on budget. There was some work left with the in-water work for the intake protection piles. These were not able to be driven to the expected depth during the first phase of construction. There was also landscaping work that was not completed because of stormwater management challenges encountered at the lower site.

Phase 1.5 GMP Development and Review

Phase 1.5 construction work includes the following:

- Upper site utility work (moved from Phase 2)
- Lower site drainage improvements (new work)
- In-water work (moved from Phase 1)

Kiewit conducted extensive outreach for the work, including outreach to twelve subcontractors for the in-water work. Two in-water work proposals were received on April 29, 2022. Only one proposal could be scored and reviewed as the other bidder was deemed non-compliant by the bidding standards. An open-book competitive bidding process was used for subcontracted work and negotiated pricing was required for potential self-perform work.

- Upper Site Utilities used both an Invitation to Bid (ITB) (for subcontracted work) and negotiated CM/GC self-perform work. Subcontracted work included pavement, vibration monitoring, off-haul of spoils, vacuum truck, hydroseeding, cathodic protection, and street sweeping.
- Lower Site Drainage Improvements used both ITB (for subcontracted work) and negotiated CM/GC self-perform work. Subcontracted work included landscaping and pavement.

Kiewit submitted an initial draft GMP for the Upper Site Utility and Lower Site Drainage Improvements in April 2022. A thorough review of the GMP No. 1.5 information was completed by WWSP staff and subject matter experts.

Early purchase of critical material was authorized to allow the contractor to have the required materials on-site for the anticipated notice to proceed. The critical materials had long lead times and included:

- Sanitary sewer piping
- Potable water piping
- Fire hydrants
- Stormwater piping
- Overflow structures and swale subdrains

Phase 2 GMP is being developed, construction work will include the following:

- New upper site electrical building
- Surge equipment
- Upper site civil improvements
- WWSS pumps, motors drives
- WWSS pump mechanical equipment
- WWSS pump bearing lubrication system

Budget Impact:

The change amount for GMP No. 1.5 is \$3,012,640, which includes two percent CM/GC contingency and five percent Owner contingency held within the contract. The total estimated cost with a three percent project contingency (held outside the contract) is \$3,103,018.76 and is within the Baseline 7.0 project budget.

Current Contract Value (includes all approved changes)	\$ 49,620,374.30
GMP No. 1.5 (including CM/GC and Owner's Contingency*)	\$ 3,012,639.57
Proposed Contract Value	\$ 52,633,013.87

*WWSP's standard approach with CM/GC contracts is to include CM/GC and Owner's contingency within the contract. An additional three percent contingency is recommended to be held outside of the contract.

- CM/GC contingency – 2% or \$52,948 (included in GMP No. 1.5)
- Owner's contingency – 5% or \$129,869 (included in GMP No. 1.5)
- Project-level contingency – 3% or \$90,379 (held outside contract)

The following is a summary of the estimated share of the total GMP No. 1.5 cost (including project contingency) by WWSS partner:

Estimated Partner Share of Proposed GMP No. 1 Cost¹	\$3,103,019
<i>TVWD Estimated Share²</i>	<i>\$1,511,524</i>
<i>Hillsboro Estimated Share²</i>	<i>\$870,188</i>
<i>Beaverton Estimated Share²</i>	<i>\$137,312</i>
<i>WIF Estimated Share²</i>	<i>\$583,995</i>

¹Includes Project-level Contingency of 3% for GMP No. 1.5

²Based on overall project ownership percentage from Baseline 7.0 budget and WWSS IGA and adjusted for specific project work elements.

Staff Contact Information:

David Kraska, P.E., WWSP Program Director; 503-941-4561; david.kraska@tvwd.org

Mike Britch, P.E., WWSP Engineering & Construction Manager; 503-941-4565; mike.britch@tvwd.org

Attachments:

- Exhibit 1: Proposed Change Order to RWF_1.0 CM/GC Contract No. 2018-013: "PCO-85 GMP-1.5 Summer Work"

Willamette Water Supply System Commission

(this page intentionally left blank)

Change Title: GMP 1.5 Summer Work
Project: RWF_CMGC
To:

Change Order# 37
Date: 5/11/2022
Contract #

The following PCOs are hereby incorporated into the Contract:

PCO#	Description	Time Impact (Days)	Change Amount
PCO - 85	GMP-1.5 Summer Work	0	\$3,012,639.57

The Original Contract Sum was	\$49,592,099.30
Net Change by Previously Authorized Requests and Changes	\$28,275.00
The Contract Sum Prior to this Change Order was	\$49,620,374.30
The Contract Sum will change by	\$3,012,639.57
The New Contract Sum including this Change Order	\$52,633,013.87
The Contract Time will change by	0 Days
The Date of Contract Completion as of this Change Order Therefore is	12/3/2024

The compensation amount of this Change Order, including time and price, comprises the total compensation due the Contractor, its Subcontractors, Suppliers, or any other party for whom Contractor is responsible, for the work or change defined in the Change Order, including impact on unchanged Work, and is all inclusive of any additional costs incurred by the Contractor to date. By executing this Change Order, the Contractor acknowledges and agrees on behalf of itself, its Subcontractors, Suppliers, and any other party for whom Contractor is responsible, that the stipulated compensation includes payment for all work contained in the Change Order, plus all payment for the interruption of schedules, extended field overhead costs, delay, and any costs resulting from, arising out of, in connection with, or impacting all other Work under this Contract. The execution of this Change Order constitutes full satisfaction and total equitable adjustment for the change. No further claim or request for equitable adjustment of any type for any reasonably foreseeable cause shall arise out of or as a result of this Change Order on the remainder of the Work under this Contract. All rights, without exception or reservation of any kind whatsoever, to file any further claim related to this Change Order are hereby waived.

OWNER

By: _____
Name: _____
Title: _____
Date: _____

By: _____
Name: _____
Title: _____
Date: _____

**PCO-85 Contract No. 2018-013
RWF_1.0 Construction Management / General Contractor Services**

CMGC contract deliverables and construction of RWF

In accordance with the contract agreement, this change authorizes the not to exceed, Guaranteed Maximum Price (GMP) of \$3,012,639.57 for the RWF_1.0 Construction Phase 1.5. The following documents are provided as back-up for GMP 1.5:

1. Lower Site Drainage Mods Quote Package
2. Price RWF 1.0 Upper Site Utilities Scope FINAL 3-24-2022
3. RWF_1.0 GMP 1.5_04072022
4. RWF_1.0 Lower Site Drainage Mods_BOE
5. RWF_1.0 Protection Piles Design Package
6. RWF_1.0 Upper Site Utilities_Scope_MarkedUp
7. RWF_1.0 Upper Site Utilities BOE
8. RWF Lowsite Drainage Modifications ChangeOrder_REV
9. 04.29.22 Raw Water Intake Piledriving Proposal (Bergerson Construction)

Item	Description	Quantity	Units	Unit Price	Net Amount
401	Upper Site Utility Work - WWSS			\$ 0.00	\$1,456,672.00
402	Allowance-Upper Site Utility Work - WWSS			\$ 0.00	\$141,921.00
403	Lower Site Drainage Improvements - WWSS			\$ 0.00	\$414,793.00
404	In-Water Work - WIF			\$ 0.00	\$570,494.50
405	Allowance-In-Water Work - WIF			\$ 0.00	\$13,500.00
406	Kiewit Fee (8%)			\$ 0.00	\$209,305.25
407	Gross Receipt Tax			\$ 0.00	\$5,202.00
600	CM/GC Contingency (Allowance)			\$ 0.00	\$51,947.61
500	Owner Contingency (Allowance)			\$ 0.00	\$129,869.03
408	Bonds and Insurance			\$ 0.00	\$18,935.18

Total	\$	3,012,639.57
--------------	-----------	---------------------

Willamette Water Supply System Commission

(this page intentionally left blank)

Willamette Water Supply
Our Reliable Water

4.A. Approve RWF_1.0 GMP 1.5 for Construction
Management Committee Meeting – *Mike Britch*

WWSS Commission Board Meeting
June 2, 2022

1

Agenda

- Background
- Scope of Work
- Bidding Process
- Cost Evaluation and Bid Results
- Cost Summary
- Benefits of Summer Work
- Requested Action

2

RWF_1.0 Project Background

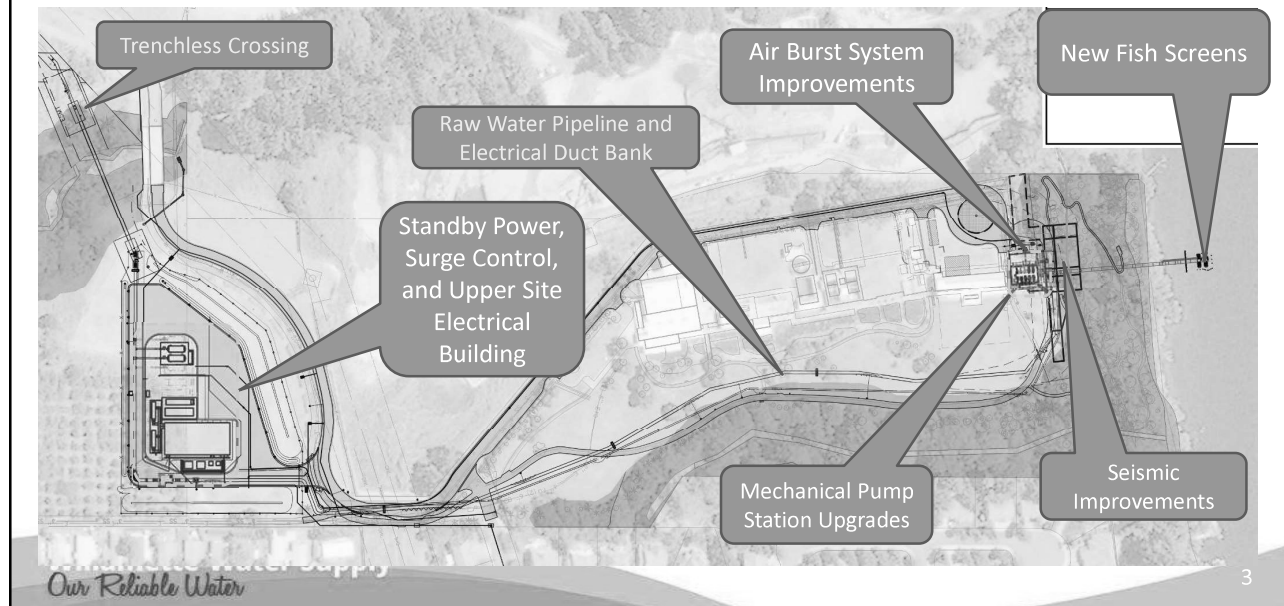

3

RWF_1.0 CM/GC Background

- Kiewit contract CM/GC services was executed in June 2018
 - Included design phase services
 - Included preparing Guaranteed Maximum Price (GMP) proposals :
 - GMP No.1 for Phase I - Executed April 2020 for \$49 M (Complete)
 - **GMP No. 1.5 for work moved from Phase 1, work moved from Phase 2, and new work**
 - GMP No.2 for Phase 2 – for remaining bid packages
 - Contract will be amended for all GMPs

4

Scope of Work (Upper Site Utilities)

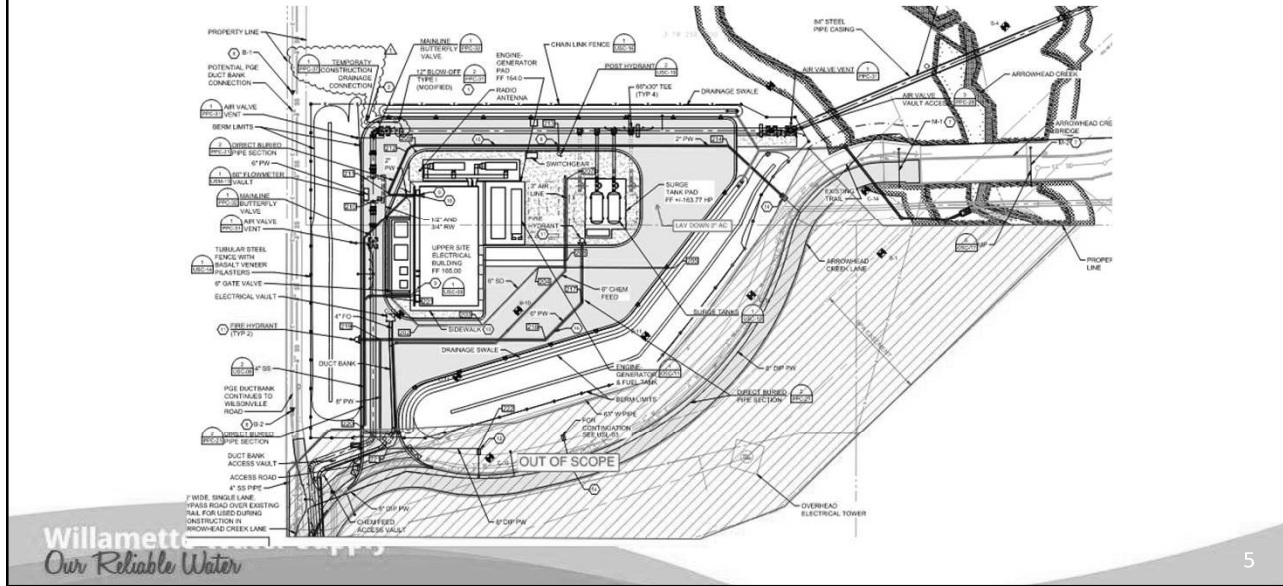

5

Scope of Work (In-Water Work)

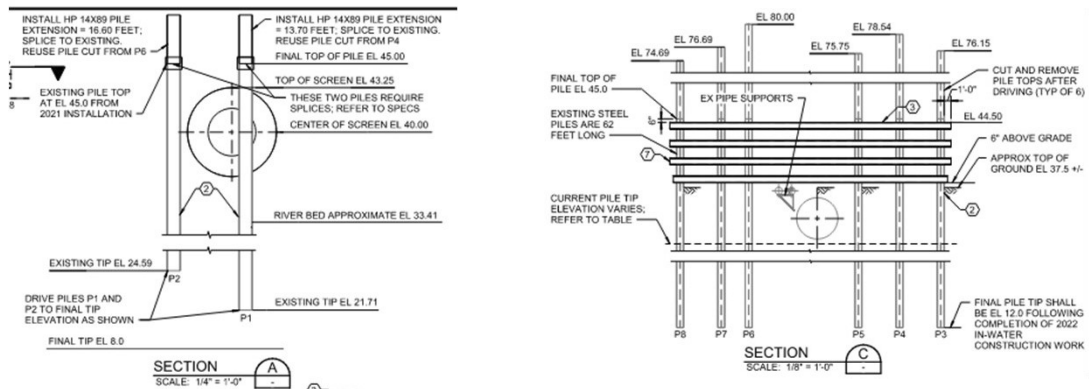

6

6

Scope of Work (Lower Site Drainage Improvements)

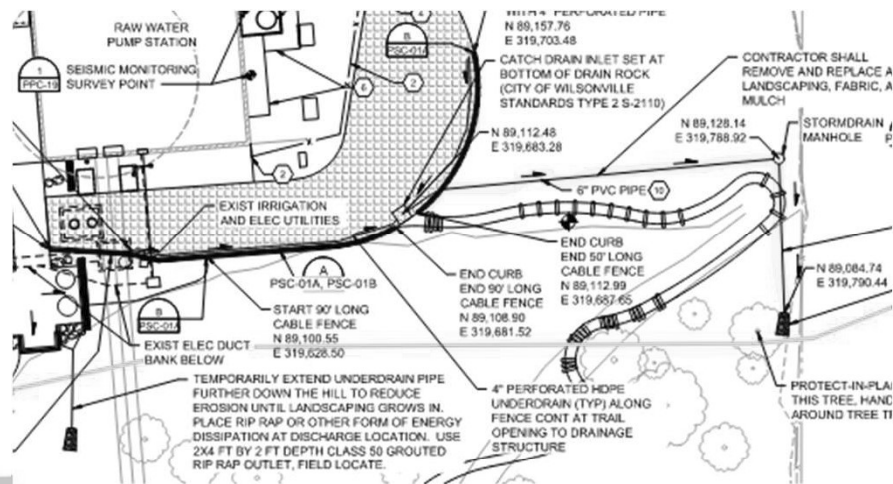

Willamette
Our Reliable Water

7

7

Bidding Process

- Upper site utilities
 - Negotiated CM/GC self-performed work
 - Sub-contracted work bid out (pavement, vibration monitoring, off-haul spoils, vacuum truck, hydroseed, cathodic protection, and street sweeping)
- In-water work
 - Outreach to twelve contractors
 - Best value proposal
- Lower site drainage improvements
 - Negotiated CM/GC self-performed work
 - Sub-contracted work bid out (landscaping and pervious asphalt)

Willamette Water Supply
Our Reliable Water

8

8

Cost Evaluation and Bid Results

- Upper site utilities
 - Negotiated within 5% of independent estimate
- In-water work
 - One responsive proposal
 - Bid less than estimated cost
- Lower site drainage improvements
 - Negotiated within 1% of independent estimate

Contract Summary

Current Contract Value (includes all approved changes)	\$ 49,620,374.30
GMP No. 1.5 (including CM/GC and Owner's Contingency*)	\$ 3,012,639.57
Proposed Contract Value	\$ 52,633,013.87

*WWSP's standard approach with CM/GC contracts is to include CM/GC and Owner's contingency within the contract. An additional three percent contingency is recommended to be held outside of the contract.

- CM/GC contingency – 2% or \$52,948 (included in GMP No. 1.5)
- Owner's contingency – 5% or \$129,869 (included in GMP No. 1.5)
- Project level contingency – 3% or \$90,379 (held outside contract)

Estimated costs are within Baseline 7.0 project budget

Estimated Cost: Contract and Recommended Contingency

Estimated Partner Share ¹	Total \$3,103,019
<i>TVWD Estimated Share²</i>	\$1,511,524
<i>Hillsboro Estimated Share²</i>	\$870,188
<i>Beaverton Estimated Share²</i>	\$137,312
<i>WIF Estimated Share²</i>	\$583,995

¹Includes Project-level Contingency of 3% for GMP No. 1.5

²Based on overall project ownership percentage from Baseline 7.0 budget and WWSS IGA and adjusted for specific project work elements.

11

Benefits of Work

- Reduces schedule risk
- Saves approximately \$330,000 in construction escalation and stormwater prevention plan costs
- Enables schedule flexibility for weather-dependent work
- Completes City of Wilsonville requirements to turnover the pathway to the lower overlook

12

QUESTIONS?

13

4.A. Requested Board Action

Consider approving a change to contract 2018-013 for \$3,012,640 with Kiewit Infrastructure West, Co. to incorporate Guaranteed Maximum Price (GMP) No. 1.5 for construction of the RWF_1.0 Facilities Construction of the Willamette Water Supply Program

14

Willamette Water Supply System Commission

(this page intentionally left blank)

STAFF REPORT

To: Board of Commissioners

From: Dave Kraska, P.E., Willamette Water Supply System General Manager

Date: June 2, 2022

Subject: Approval of Stantec Consulting Services Inc. (Stantec) Annual Work Plan (AWP) for Program and Construction Management Support Services for Fiscal Year 2023; WWSP Agreement No. WWSP-0715

Requested Board Action:

Consider approving an Annual Work Plan for Stantec Consulting Services Inc. to provide Program and Construction Management Support Services during Fiscal Year 2023 (FY2023).

Key Concepts:

- Implementing the Willamette Water Supply Program (WWSP) requires substantial assistance from a consultant with expertise and personnel to provide program and construction management support services.
- The proposed AWP identifies Stantec's planned services, planned staffing, estimated fees, and key assumptions for delivery of program and construction management support services for the WWSP for FY2023.
- This AWP corresponds to the planned WWSP activities and milestones in proposed Baseline 7.0, including approved changes through March 31, 2022, and fulfills the requirements and intent of WWSP Agreement No. WWSP-0715.
- The proposed FY2023 AWP authorization request is \$24,247,175, which is consistent with Baseline 7.0.

Background:

Stantec¹ was selected, through a competitive process that included qualifications, approach, and cost, to provide the WWSP with program management support services. The program management support services contract was approved and awarded in July 2015. Stantec was also selected, through a separate competitive process that included qualifications, approach, and cost, to provide the WWSP with construction management support services. The construction management support services were added to the program management support services contract via an amendment approved and awarded in October 2017. The program and construction management support services contract has a total term of 11.5 years (ending December 31, 2026). The contract establishes a comprehensive scope of services to support the WWSP over the term of the contract. Planned services, planned staffing, estimated fees, and key assumptions for delivery of program and construction management support services are defined and authorized on a fiscal year basis through an AWP.

¹ Stantec Consulting Services Inc. purchased MWH Americas, Inc., which was the originally contracted firm. The assignment of WWSP Agreement No. WWSP-0715 from MWH Americas, Inc. to Stantec was recognized via a contract amendment in October 2017.

The annual WWSP baseline budget and schedule update process forecasts WWSP costs through the life of the program. Planned program and construction management support services correspond to the activities and milestones identified in the WWSP Master Program Schedule and Budget Baseline. Program and construction management support needs may change as the WWSP progresses and new information becomes available. The FY2023 Program and Construction Management AWP is based on Baseline 7.0 that was approved by the Willamette Water Supply System (WWSS) Commission at its March 3, 2022, meeting and includes services for each of the following work categories:

1. General Program Management
2. Risk Management
3. Procurement and Contract Administration
4. Quality Assurance
5. Program Controls and Document Management
6. Design Management
7. Construction Management, Construction Inspection, & Safety/Security
8. Facility Testing and Commissioning
9. Permitting Support
10. Land and Right-of-Way Acquisition Support
11. Public Outreach and Public Affairs Support

WWSP projects (or work packages) with substantial anticipated activities for the period of the FY2023 AWP are as listed in the table below.

Projects in Design	Projects in Construction
No design activity, other than design-related support for construction, commissioning, and start-up, is planned for this period	PLM_1.3 (progress construction) PLM_4.1 (progress construction with Washington County) PLM_4.2 (progress construction with Washington County) PLM_4.3 (progress construction) PLM_4.4 (progress construction with Washington County) PLW_1.2 (progress construction with Washington County) PLW_1.3 (closeout construction) PLW_2.1 (procure construction contractor; begin and progress construction) MPE_1.1 ¹ (complete construction with the City of Beaverton) MPE_1.2 ¹ (progress construction) MPE_1.3 (progress construction) RWF_1.0 (execute GMP 2; begin phase 2 construction) WTP_1.0 ² (progress construction) RES_1.0/PLM_5.3 (progress construction)

1. WTP_1.0 includes FPS_1.0 and DCS_1.0 for purposes of the AWP.
2. MPE_1.1 includes COB_1.1 and MPE_1.2 includes COB_1.2 for the purposes of the AWP.

This AWP represents 37 percent increase in hours and a 36 percent increase in budget when compared to the FY2022 (current) AWP. This increase is primarily due to the additional construction management staff necessary to manage the thirteen projects currently in construction and two additional projects entering the construction phase in FY2023.

Budget Impact:

The proposed FY2023 AWP would authorize fees up to \$24,247,175 during FY2023. This amount is reflected in WWSP Baseline 7.0, which was approved by the Board on March 3, 2022. The table below shows the estimated distribution of the proposed budget based on cost shares presented in Baseline 7.0:

Stantec FY 2023 Program and Construction Management Services AWP Budget		\$24,247,175
<i>TVWD Estimated Share</i>	<i>\$14,899,213</i>	
<i>Hillsboro Estimated Share</i>	<i>\$7,763,134</i>	
<i>Beaverton Estimated Share</i>	<i>\$1,549,969</i>	
<i>Willamette Intake Facilities Commission Estimated Share*</i>	<i>\$34,859</i>	

*Other Willamette Intake Facility Partners Only (Sherwood, Tigard, and Wilsonville)

Staff Contact Information:

David Kraska, PE; Willamette Water Supply Program Director; 503-941-4561; david.kraska@tvwd.org

Attachments:

- Exhibit 1: Program and Construction Management Services Fiscal Year 2022-2023 AWP

Willamette Water Supply System Commission

(this page intentionally left blank)



DATE: February 11, 2022 (initial draft)
April 26, 2022 (second submittal)
May 12, 2022 (third submittal)
[Effective July 1, 2022]

TO: David Kraska, WWSP Program Director

FROM: Jeremy Taylor, WWSP Program Manager

SUBJECT: Annual Work Plan – Fiscal Year 2022-2023 (July 1, 2022 through June 30, 2023),
Willamette Water Supply Program, Agreement No. WWSP-0715 (as amended)

INTRODUCTION

This Annual Work Plan (AWP) identifies Stantec’s planned services, planned staffing, estimated fees, and key assumptions for delivery of program and construction management support services for the Willamette Water Supply Program (WWSP) for Fiscal Year 2022-2023, which extends from July 1, 2022 through June 30, 2023. This AWP fulfills the requirements and intent of the subject Agreement.

PLANNED SERVICES

Program and construction management services planned for this AWP period are identified in Table 1. We recognize that due to the complex nature and long duration of the WWSP, program and construction management support needs may change as the program progresses and new information becomes available. The planned services represent our understanding of current WWSP needs for the AWP period.

PLANNED STAFFING

Planned staffing to provide the planned services for this AWP is identified in Table 2.1-2.3. These tables include the name, role, and planned labor hours by major program task for personnel identified for the planned services. In instances where a specific individual has not yet been identified, a role and planned labor hours are identified. Specific personnel to support the WWSP shall be identified in writing and authorized by the WWSP Program Director in accordance with Article 1.1.5 of the Agreement. The personnel and labor hours within this AWP represent our understanding of the strategic, technical, and administrative requirements for delivering the planned services. Actual requirements will vary and Stantec will adjust the staffing and distribution of labor hours within this AWP accordingly to maintain progress toward delivery of the WWSP.

ESTIMATED FEES

Estimated fees for providing the planned services using the planned staffing within this AWP are identified in Table 3.1-3.3. These tables include planned personnel; hourly pay rate, PMO, part-time support, or field billing rate factor (as appropriate); planned labor hours; and estimated fees. In instances where specific personnel have not yet been identified, an assumed hourly pay rate is included. The table also includes estimated reimbursable expenses associated with the planned services and planned personnel. Material changes to the planning represented by this AWP may result in changes to the estimated fees. Such changes would be managed in accordance with Article 5 of the Agreement.

KEY ASSUMPTIONS

This AWP is based on a number of assumptions about WWSP delivery needs during Fiscal Year 2022-2023. The following key assumptions apply to this AWP:

- Planned program and construction management services for this AWP correspond to the activities and milestones identified in the WWSP Master Program Schedule and Budget Baseline 7.0 including approved changes through March 31, 2022 (summary attached).
- WWSP projects (or work packages) with substantial anticipated activities for the period of this AWP are as listed in the table below. The amount of construction planned for this period is substantially greater than for prior years.

Projects in Design	Projects in Construction
No design activity, other than design-related support for construction, commissioning, and start-up, is planned for this period	PLM_1.3 (progress construction) PLM_4.1 (progress construction with Washington County) PLM_4.2 (progress construction with Washington County) PLM_4.3 (progress construction) PLM_4.4 (progress construction with Washington County) PLW_1.2 (progress construction with Washington County) PLW_1.3 (closeout construction) PLW_2.1 (procure construction contractor; begin and progress construction) MPE_1.1 ¹ (complete construction with the City of Beaverton) MPE_1.2 ¹ (progress construction) MPE_1.3 (progress construction) RWF_1.0 (execute GMP 2; begin phase 2 construction) WTP_1.0 ² (progress construction) RES_1.0/PLM_5.3 (progress construction)

1. MPE_1.1 includes COB_1.1 and MPE_1.2 includes COB_1.2 for the purposes of the AWP.
2. WTP_1.0 includes FPS_1.0 and DCS_1.0 for purposes of the AWP.

- Labor hours, assumed direct labor rates, and assumed budgets for unnamed technical experts and specialists are carried within the “Program Controls and Document Management”, “Design Management” and the “Construction Management, Construction Inspection, & Safety/Security” tasks but may be used to meet identified resource needs within any task.
- The resources and associated level of effort/estimates shown for each task may vary if the scope or timing is modified or if the level of resourcing from the Participants’ organizations is modified.

- At the direction of the Program Director, Stantec can assist the Participants with other activities/projects within the overall Statement of Work as required, should that assistance be within the budgetary limits of this AWP or an approved amendment.
- It is anticipated some work and priorities will change over the course of this AWP period. Stantec will only perform supplemental services as authorized in writing by the Program Director. Stantec will not begin any supplemental service until the Program Director has reviewed the services, proposed resources/level of effort, and estimated cost and has authorized Stantec to proceed.

APPROVAL

The WWSP Participants approve this AWP.

David Kraska, P.E.
Program Director

Date

Table 1. Planned Program Management Support Services – Fiscal Year 2022-2023 (July 1, 2022 through June 30, 2023).

Task No. ¹	Task Name	Primary WWSP Projects/Initiatives ²	Planned Services	Key Resources ³
1.2	General Program Management	<ul style="list-style-type: none"> Overall management of WWSP Delivery and resourcing in accordance with the Fiscal Year 2022-2023 Master Program Schedule and Budget Baseline Participation in WWSS and WIF Board, Management Committee, Management Team, Public Affairs, other progress, and coordination meetings 	<ul style="list-style-type: none"> Support Participants’ management of WWSP implementation as directed by the Program Director Coordinate execution of the Program Management Plan (PgMP) and delivery of WWSP in alignment with the Fiscal Year 2022-2023 Master Program Schedule and Budget Baseline Revise Delivery Strategy as necessary following the change management program Participate in ongoing leadership and management meetings Conduct regular program review meetings and monthly progress meetings with Program Director Manage program resources and provide necessary technical, management, and support resources to meet the goals and objectives of the WWSP; acquire/relocate resources as approved by Program Director Coordinate with Participants’ public outreach/affairs staff and consultants to support the outreach program Participate in Participants' leadership, Boards, City Council, and Utilities Commission meetings as requested Communicate and work with internal and external stakeholders in coordination with the WWSP Permitting and Outreach Manager Work with Participants’ legal counsel, Program Director, and other key staff to support completion and implementation of various agreements for projects as requested Maintain monthly reporting with correlating metrics for comparison and validation Prepare semi-annual Business Utilization economic benefits reports Review the PgMP and prepare an annual update to PgMP sections as needed 	<p>Jeremy Taylor Virginia Anderson Elnaz Adeh</p> <p>TBD Technical Experts and Specialists (as needed)</p>
1.3	Internal/Participants Governance Process	Included in 1.2 General Program Management and 2.3 Public Outreach and Public Affairs Support	N/A	N/A
1.4	Risk Management	<ul style="list-style-type: none"> Overall Program Active design and construction projects <p>[Estimated costs for implementing this task are included in other tasks (e.g., 1.2 Program Management and 1.5 Program Controls)]</p>	<ul style="list-style-type: none"> Execute, and identify updates and improvements where needed, Risk and Value Management Plan Participate in executing the Program Risk Management Plan Maintain separate risk registers for individual projects (Project-level) and for the Program as a whole (Program-level) Apply qualitative and quantitative methods for identification and analysis of program and project risks in terms of cost and schedule Develop program and project risk responses and mitigation strategies Use risk management process to evaluate Program and project contingencies Analyze potential or actual construction claims as needed Prepare quarterly (or as otherwise requested by the Assistant Program Director) risk management information for the Program Director and Management Committee Conduct project risk reviews as indicated in the Project Delivery System Support evaluations of Notices of Intent to Change 	<p>Elnaz Adeh</p> <p>TBD Technical Experts & Specialists (as needed)</p> <p>TVWD will provide an Asst. Program Director to support this task</p>

Task No. ¹	Task Name	Primary WWSP Projects/Initiatives ²	Planned Services	Key Resources ³
1.6	Procurement and Contract Administration	<ul style="list-style-type: none"> • PLW_2.1 (construction contractor) • RWF_1.0 construction (CMGC GMP 2 development) • WTP_1.0 construction (CMGC GMP 2 development) • Incidental program support services as needed • Construction testing services as needed • Amendments, changes, and close-out for existing contracts/ agreements 	<ul style="list-style-type: none"> • Implement the Procurement and Contract Administration Management Plan • Participate in executing the Program Controls and Document Management Plan, Construction Management Plan, Value and Risk Management Plan, the Quality Management Plan, Water Infrastructure Finance and Innovation Act (WIFIA) Compliance Plan, and the change management process • Provide strategic advice and tactical support for Program procurements • Maintain and update construction contract templates for conventional design-bid-build and Construction Manager/General Contractor • Lead procurement activities for self-performed bid packages for CM/GC contracts • Coordinate with other Program functions to address procurement needs • Monitor local, state, and federal laws pertaining to procurement and contract administration. Communicate relevant changes to Participants, including recommended modifications to procurement and contract administration practices • Support the development of the draft and finalize Deferred Project Plan (e.g., PLW_2.2 status, document inventory, estimate, procurement strategy etc.) 	<p>Doug Shermack</p> <p>TBD Technical Experts and Specialists (as needed)</p>
1.8	Quality Assurance	<ul style="list-style-type: none"> • Overall Program • Construction of PLM_1.3, PLM_4.1, PLM_4.2, PLM_4.3, PLM_4.4, PLW_1.2, PLW_1.3, PLW_2.1, MPE_1.1, MPE_1.2, MPE_1.3, RWF_1.0, RES_1.0-PLM_5.3, & WTP_1.0 • Permitting and environmental services contract <p>[Estimated costs for implementing this task are included in other tasks (e.g., 2.1 Permitting Support, 1.10 Design Management, and 1.11 Construction Management)]</p>	<ul style="list-style-type: none"> • Execute the Quality Management Plan (QMP) and identify updates and improvements where needed • Establish and implement an annual schedule for reviewing compliance with WWSP QMP • Review quality plans submitted by current consultants and construction contractors, and establish and implement a schedule for reviewing compliance with those plans • Maintain quality management procedures for project transitions between design and construction • Include quality requirements in procurement documents (refer to 1.6 Procurement and Contract Administration) • Plan and participate in factory witness inspection for pipe fabrication as needed • Plan and participate in seismic certification witness testing and otherwise support as needed • Provide administrative/technical writing or graphics staff as needed • Provide ongoing quality management guidance to PMO personnel 	<p>Scott Gibson (Program & Design/Engineering Services During Construction)</p> <p>Andre Tolme (Construction)</p> <p>Jill Chomycia (Permitting)</p> <p>TBD Technical Specialists (as needed)</p>

Task No. ¹	Task Name	Primary WWSP Projects/Initiatives ²	Planned Services	Key Resources ³
1.5, 1.9	Program Controls and Document Management	<ul style="list-style-type: none"> Overall Program Active contracts/agreements Construction of PLM_1.3, PLM_4.1, PLM_4.2, PLM_4.3, PLM_4.4, PLW_1.2, PLW_1.3, PLW_2.1, MPE_1.1, MPE_1.2, MPE_1.3, RWF_1.0, RES_1.0-PLM_5.3, & WTP_1.0 	<ul style="list-style-type: none"> Execute and identify updates and improvements where needed, Program Controls and Document Management Plan and WIFIA Compliance Plan Maintain document management systems and procedures Manage financial and cost reporting systems and procedures Maintain a Master Program Schedule and Budget Baseline, including monthly updates and incorporation of approved changes Prepare an annual reforecast of the Master Program Schedule and Budget Baseline Submit draft budget information for fiscal year 2023-2024 (a 90%± accuracy budget recommendation is due 12/31/22 and a final budget recommendation is due February 2023) Review and validate Stantec’s Fiscal Year 2023-2024 Annual Work Plan (in late May or early June 2023) with the Program Director to confirm that assumptions about Program needs made in January 2023 remain valid for the upcoming fiscal year Perform analyses of consultant and construction contractor schedule submittals to verify alignment with contractual obligations and identify risks and inconsistency with Program objectives Manage and support the change management process, including participating in Change Committee meetings and maintaining records of potential and actual changes Produce standard controls reports for Management Committee, Program Director, and project teams and ad hoc reports as requested Provide ongoing support for systems, tools, and procedures, including e-Builder maintenance, modifications, and enhancement requests Support extension of e-Builder to partner project owners as applicable Support development and implementation of processes to comply with conditions of the Participants’ WIFIA loans Support other Program functions as required in document, cost, and reporting needs Support WWSS/WIF financial policy/procedure project as needed Manage invoicing process 	<p>Ellen Peterman Rich Edwards Dan Peterson Brittney Oseth</p> <p>TBD Technical Experts and Specialists (as needed)</p> <p>TVWD will provide a full-time document control specialist to support this task</p>
1.10	Design Management	<ul style="list-style-type: none"> Construction of PLM_1.3, PLM_4.1, PLM_4.2, PLM_4.3, PLM_4.4, PLW_1.2, PLW_1.3, PLW_2.1, MPE_1.1, MPE_1.2, MPE_1.3, RWF_1.0, RES_1.0-PLM_5.3, & WTP_1.0 	<ul style="list-style-type: none"> Execute the Design Management Plan Participate in executing the Construction Management Plan, Value and Risk Management Plan, the Quality Management Plan, WIFIA Compliance Plan, and the change management process Manage the scope, schedule, and budget for ongoing projects Support construction management, including submittals review and change management, for listed construction projects Develop and implement project-specific interim operational plans as projects are completed Maintain and revise Program Pipeline Design Guide as necessary (incorporate Program seismic standards) Modify and update standard details and specifications as appropriate based on experience gained during construction and integrate across all projects to maintain consistency across program Support the development or amendment of construction IGAs with Washington County (and other potential project partners) as applicable Provide Geographical Information System and Computer-Aided Drawing support as needed (assumes Participants will typically provide GIS services) Support coordination with BPA, PGE, NW Natural, and other utility stakeholders Draft and finalize Deferred Project Plan (e.g., PLW_2.2 status, document inventory, estimate, procurement strategy etc.) Manage system-wide planning of operations from interim to commissioning to on-going operations, and review compatibility of design to support each operational phase (this task is in conjunction with Task 1.13 Facility Testing and Commissioning) Finalize the System Control Strategy and monitor implementation throughout the construction phase Support emergency response plan (and other related plans) development Provide support for acquisition of spare parts including emergency repair parts 	<p>Scott Gibson Project Managers Assistant Project Managers</p> <p>TBD Technical Experts and Specialists (as needed)</p> <p>TVWD will provide a full-time Geographic Information Systems analyst.</p>

Task No. ¹	Task Name	Primary WWSP Projects/Initiatives ²	Planned Services	Key Resources ³
<p>1.7, 1.11, 1.12</p>	<p>Construction Management, Construction Inspection, & Safety/Security</p>	<ul style="list-style-type: none"> • Construction (via WWSP contractor) of PLM_1.3, PLM_4.3, PLW_1.3, PLW_2.1, MPE_1.2, MPE_1.3 RWF_1.0, WTP_1.0, & RES_1.0-PLM_5.3 • Construction (via Washington Co. contractor) of PLM_4.1, PLM_4.2, PLM_4.4, & PLW_1.2 • Construction (via City of Beaverton) of MPE_1.1 • WWSP health and safety program 	<ul style="list-style-type: none"> • Provide program-level and field services on the listed construction projects to: <ul style="list-style-type: none"> ○ Execute and identify updates and improvements, where needed, to the Construction Management Plan ○ Provide construction management, inspection, and oversight of materials testing ○ Provide ongoing review of standard construction details and work with Design Manager and Design Consultant to recommend, review, and implement changes ○ Execute Project Execution Plans ○ Administer construction contracts in coordination with the City of Beaverton, Washington County, and other project partners as appropriate ○ Coordinate construction management resources, including materials testing/special inspection/contractors ○ Organize and manage WWSP construction meetings and attend partner project construction meetings ○ Manage construction project documentation, including RFIs, Submittals, Work Change Directives, Design Clarifications, Daily Reports, photographs, and other construction-related correspondence ○ Support procurement of required services during construction ○ Administer construction change management process during construction ○ Review contractors pay applications, coordinate resolution of issues, and recommend payment ○ Estimate cost of potential construction changes as needed ○ Maintain a working set of “as-built” drawings during construction ○ Conduct quantity tracking for selected progress indicators as requested (e.g., length of pipeline installed) during construction ○ Manage potential/actual contractor claims and coordinate legal services input on contractor claims ○ Manage and track overall project construction schedules and related issues ○ Manage interface and coordination between adjacent projects ○ Support the implementation of interim operational plans at the end of construction with commissioning and startup plans ○ Support periodic on-site visits to construction sites by WWSP, TVWD, Hillsboro, and Beaverton staff and others as necessary ○ Organize necessary documents and information about projects in support of project closeout • Participate in executing and updating (where needed) other Program plans, including the Design Management Plan, Value and Risk Management Plan, Quality Management Plan, Public Outreach and Stakeholder Engagement Plan, Permitting Management Plan, and Program Controls Plan • Support WWSP and Washington County contractor procurements • Manage WWSP Health and Safety program in accordance with WWSP Health and Safety Plan • Coordinate and assist with preparation of WWSP-related safety reports, including OSHA required reporting • Support the development and amendment of construction IGAs with Washington County (and other potential project partners) as applicable • Coordinate with all Program functions (e.g., Design and Permitting) as required • Prepare or review Opinions of Probable Construction Cost, including those associated with construction changes • Participate in Notices of Intent to Change • Participate in Program and construction reporting and make recommendations to incorporate additional reporting or delete reporting as projects progress • Support the implementation of the warranty management plan as requested 	<p>Andre Tolme Chad Carlson Eric Fullan Milton Stamp John Uhrin Construction Managers, Field Inspectors, and Construction Management Specialists as identified in the tables below</p> <p>TBD Technical Experts and Specialists (as needed)</p> <p>TVWD will provide a part-time safety and security supervisor to support this task</p>

Task No. ¹	Task Name	Primary WWSP Projects/Initiatives ²	Planned Services	Key Resources ³
1.13	Facility Testing and Commissioning	<ul style="list-style-type: none"> • Overall Program • Active design and construction projects • Water supply integration planning & operations planning <p>[Estimated hours/cost for other resources such as Design Managers, Project Managers, and permitting staff, are included in the primary tasks for those resources.]</p>	<ul style="list-style-type: none"> • Review design and construction deliverables for specified testing and training requirements and equipment selection • Participate in the development and implementation of project-specific interim operational plans as projects are completed • Lead overall WWSS operational planning and development • Implement a warranty management plan • Coordinate between interim operational plans and commissioning and startup plan • Manage the development of System-wide testing, commissioning, and start-up plan (Under the current WTP contract, this plan will be developed by the WTP CM/GC and progressively elaborated over multiple years. However, modifications to the WTP CM/GC's scope to limit planning responsibility to the raw water system, WTP, and a point on the finished water system near the WTP are likely but have not yet been defined.) • Develop final Commissioning and Start-Up Plan, built, in part, upon draft Commissioning and Start-Up Plan with deliverables prepared by WTP CM/GC under a separate contract with Participants • Manage commissioning and start-up planning and implementation schedule • Support refinement and application of a strategy for managing water within WWSS assets prior to placement in service • Support Construction Management with review of submittal, RFIs, and design clarifications as appropriate; and documented through existing PMIS workflows • Support permitting team in obtaining approval from appropriate jurisdictions for discharge of water related to commissioning and startup • Support water supply integration planning • Support commissioning and startup activities by TVWD, Hillsboro, and Beaverton as requested 	<p>Tim Tekippe Erika Murphy</p> <p>TBD Technical Experts and Specialists (as needed)</p> <p>TVWD and City of Hillsboro will provide operations personnel to support this task</p>

Task No. ¹	Task Name	Primary WWSP Projects/Initiatives ²	Planned Services	Key Resources ³
2.1	Permitting Support	<ul style="list-style-type: none"> Overall Program Construction of PLM_1.3, PLM_4.1, PLM_4.2, PLM_4.3, PLM_4.4, PLW_1.2, PLW_1.3, PLW_2.1, MPE_1.1, MPE_1.2, MPE_1.3, RWF_1.0, RES_1.0-PLM_5.3, & WTP_1.0 	<ul style="list-style-type: none"> Execute the Permitting Management Plan and identify updates and improvements where needed Provide strategic advice and tactical support to implement the Participants' Permitting Strategy as required Coordinate and support management of permitting support contract(s) Track and report permitting, including land use, status in coordination with the Participants' permitting consultant Provide technical support and preparation for workshops (typically led by Participants' permitting consultant) with the regulatory agencies Facilitate the delivery of design and construction information to support permit (including land use) applications, supplements, amendments, and reports to be developed by the Participants' permitting consultant Coordinate with the design and construction teams, including Participants' permitting consultant, to reflect permitting (including land use) requirements in design deliverables and clarifications, where applicable. In coordination with the Participants' permitting consultant, support identification and implementation of thermal offset projects to meet WWSP water trading requirements Coordinate with design and cost-estimating staff to verify regulatory and land use agency requests and proposed commitments align with other WWSP goals Assist Construction Management and Participants' permitting consultant with addressing any permitting or compliance issues with listed construction projects Maintain a Program Formulation Summary document (as defined in the Permitting Management Plan) Incorporate permitting-related budget and schedule information (developed by Participants' permitting consultant) into Program budget and schedule, including coordination with design and construction work In coordination with the Participants' permitting consultant, maintain a permit (including land use) tracking database, with correlation to Master Program Schedule Serve as permitting liaison to the Program real estate team Support startup and commissioning planning and activities as necessary Support of Thermal Trading Plan implementation Support the development or amendment of intergovernmental agreements as required (CWS operation and maintenance plan for minor blowoffs) 	<p>Jill Chomycia Meredith Jordan</p> <p>TBD Technical Experts and Specialists (as needed)</p> <p>TVWD will provide a full-time permitting and outreach manager to support this task</p>
2.2	Land and Right-of-Way Acquisition Support	<ul style="list-style-type: none"> Overall Program (Assigned) Construction of PLM_4.1, PLM_4.2, PLM_4.3, PLM_4.4, MPE_1.1, MPE_1.2, MPE_1.3, RWF_1.0, & WTP_1.0 (As requested) Construction of PLM_1.3, PLW_1.2, PLW_1.3, PLW_2.1, & RES_1.0-PLM_5.3 <p>[Estimated costs for implementing this task are included in other tasks (e.g., 2.3 Public Outreach and Public Affairs Support (Marciniak); 1.5/1.9 Program Controls and Document Management (Peterson)]</p>	<ul style="list-style-type: none"> Support Participants' execution of the Real Estate Plan and identify updates and improvements where needed Assist Participants and Participants' real estate consultant in the resolution of issues affecting acquisition of land, rights-of-way (ROWs) and easements Support Participants' real estate consultant's maintenance of a database to track rights-of-entry (ROEs), appraisals, and property/easement acquisitions Assist Participants and Participants' real estate consultant with the preparation of ROW documents and review of title reports, encumbrances, and findings from environmental site assessments to determine effects on the properties Assist with quality assurance reviews of ROW plans and easement descriptions prepared by design consultants Assist Participants to meet with property owners to apprise them of the project, provide project status, and work with Participants and Participants' real estate consultant to acquire easements 	<p>David Marciniak (property-owner contacts support) Dan Peterson (data support)</p> <p>TBD Technical Experts and Specialists (as needed)</p> <p>TVWD will provide a full-time project coordinator to support this task</p>

Task No. ¹	Task Name	Primary WWSP Projects/Initiatives ²	Planned Services	Key Resources ³
2.3	Public Outreach and Public Affairs Support	<ul style="list-style-type: none"> • Overall Program • (Assigned) Construction of PLM_4.1, PLM_4.2, PLM_4.3, PLM_4.4, MPE_1.1, MPE_1.2, MPE_1.3, RWF_1.0, & WTP_1.0 • (As requested) Construction of PLM_1.3, PLW_1.2, PLW_1.3, PLW_2.1, & RES_1.0-PLM_5.3 	<ul style="list-style-type: none"> • Execute and identify updates and improvements where needed, Public Outreach and Stakeholder Engagement Plan and Local and Regional Business Utilization Plan • Support Participants' staff as needed in its public outreach and public affairs activities • Facilitate an ongoing stakeholder identification process and development and implementation of outreach strategies and timing • Support development and implementation of property owner engagement strategies and support construction activities related to management of easements with private parties • Prepare semi-annual local and regional business involvement reports and as requested, prepare information to support public communications • Coordinate with other functions within the Program (e.g., Real Estate) • Consult on media relations and issues management • Coordinate with the water supply integration team to develop communications strategies and timing • Support construction management personnel • Support the development of the Monthly Progress Reports 	<p>David Marciniak</p> <p>TBD Technical Experts and Specialists (as needed)</p> <p>TVWD will provide a full-time communications supervisor to support this task</p>

¹ – Task numbers correspond to numbered sections within Exhibit A Statement of Work, Article II, and Article III of the Agreement. Task No. 1.1 in the Statement of Work is Mobilization and is not included herein.

² – Primary WWSP Projects/Initiatives represent the anticipated focus for the period covered by this AWP. Project codes (e.g., PLM_4.1) correspond to naming conventions used in the Master Program Schedule and Budget Baseline.

³ – Lead resources are in BOLD, other Key Resources associated with a given task are in support roles and are also leading or supporting other tasks. Refer to Table 2 for planned level of effort by resource.

Table 2.1. Planned Program Management Support Staffing Hours Summary – Fiscal Year 2022-2023 (July 1, 2022 through June 30, 2023).

Name	Role	Current Billing Rate	Current Factor	Total
Andre Tolme	Program Construction Manager		2.65	1,991
Brendan Robless	Project Manager		2.65	1,991
Brittney Oseth	Controls Specialist		2.65	1,991
Chad Carlson	Safety		2.65	1,991
Dan Peterson	Controls Specialist		2.65	1,991
David Marciniak	Public Affairs/Outreach		2.65	1,991
Doug Shermack	Procurement and Contracts Administrator		2.65	1,991
Elena Thomsen	Staff Professional		2.65	996
Elena Thomsen	Construction Management Specialist		2.65	996
Ellen Peterman	Controls Manager		2.65	1,991
Elnaz Adeh	Special Projects Manager		2.65	1,991
Eric Fullan	Safety		2.65	1,991
Erika Murphy	Project Manager		2.65	1,991
Faride Abzade	Construction Management Specialist		2.65	1,991
Jennifer Minton	Project Manager		2.65	1,991
Jeremy Taylor	Program Manager		2.65	1,991
Jill Chomycia	Permitting Coordinator		2.65	1,991
John Uhrin	Sr. Cost Estimator		2.65	1,991
Kristina McLean	Construction Management Specialist		2.65	1,991
Matthew Gribbins	Project Manager		2.65	1,991
Meredith Jordan	Permitting Specialist		2.65	1,991
Reed Featherstone	Construction Management Specialist		2.65	1,991
Rich Edwards	Scheduler		2.65	1,991
Robert McCaig	Construction Management Specialist		2.65	1,991
Scott Gibson	Design Manager		2.65	1,991
TBD Construction Management Specialist 04	Construction Management Specialist		2.65	1,991
Virginia Anderson	Administrative Assistant		2.65	1,991
Zach Barbarick	Construction Management Specialist		2.65	1,991
Aldridge Lim	Field Inspector		2.51	2,515
Bennie Bitz	Field Inspector		2.51	2,515
Bill Kistner	Field Inspector		2.51	2,515
Casey Kendall	Field Inspector		2.51	2,134
Doug Kelley	Construction Manager		2.51	1,991
Gabriel Jalbert	Construction Manager		2.51	1,991
Grant Schoepper	Construction Manager		2.51	1,991
Jerome Duletzke	Construction Manager		2.51	1,991
John Nielsen	Construction Manager		2.51	1,991
Kristina Tubbert	Field Administrative Assistant		2.51	1,991
Kyle Butler	Construction Manager		2.51	1,991
Larry Hodgson	Field Inspector		2.51	2,515
Marc Krekos	Field Inspector		2.51	2,515
Matt Nussbaumer	Field Inspector		2.51	422
Matt Pease	Construction Manager		2.51	1,991
Milton Stamp	Safety		2.51	1,991
Modena Moore	Field Inspector		2.51	2,515
Rick Hyatt	Field Inspector		2.51	2,515
Rod Warner	Construction Manager		2.51	1,991
Stephen Poage	Construction Manager		2.51	1,163
Steve Clapper	Construction Manager		2.51	1,991
TBD Field Inspector 07	Field Inspector		2.51	2,093
TBD Field Inspector 08	Field Inspector		2.51	2,314
TBD Field Inspector 10	Field Inspector		2.51	1,610
TBD Field Inspector 11	Field Inspector		2.51	1,469
TBD Field Inspector 12	Field Inspector		2.51	2,314
TBD Field Inspector 13	Field Inspector		2.51	2,515
TBD Field Inspector 14	Field Inspector		2.51	2,410
TBD Field Inspector 15	Field Inspector		2.51	2,410
TBD Field Inspector 16	Field Inspector		2.51	2,515
TBD Field Inspector 17	Field Inspector		2.51	1,610
TBD Field Inspector 18	Field Inspector		2.51	1,680
TBD Field Inspector 19	Field Inspector		2.51	2,515
TBD Field Inspector 20	Field Inspector		2.51	2,093
TBD Field Inspector 21	Field Inspector		2.51	2,515
TBD Field Inspector 22	Field Inspector		2.51	2,410
TBD Field Inspector 23	Field Inspector		2.51	1,267
TBD Field Inspector 24	Field Inspector		2.51	1,882
TBD Field Inspector 25	Field Inspector		2.51	1,258
TBD Field Inspector 26	Field Inspector		2.51	2,006
Todd Tubbert	Construction Manager		2.51	1,991
Tyler Butler	Construction Manager		2.51	1,991
Bill Van Derveer	Program Delivery (SME)		2.82	314
Emma Gentry	Technical Editor		2.82	210
Eric Biederman	Administrative Support		2.82	210
Eric Hjelle	Schedule Support		2.82	314
Eric Ward	Project Manager		2.82	1,048
Jason Rozgony	Sr. Cost Estimator		2.82	105
Jude Grounds	RWF/WTP Technical Advisor		2.82	105
Kieran Christie	Schedule Support		2.82	314
Ligia Bejarano	Administrative Assistant		2.82	210
Mike Jesionowski	Sr. Cost Estimator		2.82	105
Mike Warriner	Constructability/Schedules		2.82	419
Russell Snow	Design Manager Pipelines and Reservoirs		2.82	314
Tammy Cleys	Project Manager		2.82	692
TBD Subject Matter Experts (Various)	Subject Matter Experts (SME)		2.82	1,048
TBD Technical Staff (Various)	Technical Resources		2.82	1,991
Tim Tekippe	Testing and Commissioning Lead		2.82	524
Wes Silva	Construction Manager		2.82	914
Grand Total				148,695

¹ _ Direct Labor Rates for TBD resources shall be submitted for approval on a case-by-case basis.

² _approximately 15-20% overtime budget for Field Inspectors

Table 2.2. Planned Program Management Support Staffing for System wide Tasks – Fiscal Year 2022-2023 (July 1, 2022 through June 30, 2023).

Name	Role	Current Billing Rate	Current Factor	Program Management	Controls	WIFIA	Permitting	Procurement	Public Outreach	Design Management	SW Construction Management	Facilities Commissioning & Startup
				PROG_1.0	PROG_1.0	PROG_1.0	PROG_1.0	PROG_1.0	PROG_1.0	PROG_1.0	PROG_1.0	PROG_1.0
Andre Tolme	Program Construction Manager		2.65	-	-	-	-	-	-	-	1,991	-
Brendan Robless	Project Manager		2.65	-	-	-	-	-	-	-	-	-
Brittney Oseth	Controls Specialist		2.65	-	996	996	-	-	-	-	-	-
Chad Carlson	Safety		2.65	-	-	-	-	-	-	-	1,991	-
Dan Peterson	Controls Specialist		2.65	-	1,991	-	-	-	-	-	-	-
David Marciniak	Public Affairs/Outreach		2.65	-	-	-	-	-	1,991	-	-	-
Doug Shermack	Procurement and Contracts Administrator		2.65	-	-	-	-	1,991	-	-	-	-
Elena Thomsen	Staff Professional		2.65	-	-	-	-	-	-	-	-	-
Elena Thomsen	Construction Management Specialist		2.65	-	-	-	-	-	-	-	-	-
Ellen Peterman	Controls Manager		2.65	-	1,572	419	-	-	-	-	-	-
Elnaz Adeh	Special Projects Manager		2.65	1,991	-	-	-	-	-	-	-	-
Eric Fullan	Safety		2.65	-	-	-	-	-	-	-	1,991	-
Erika Murphy	Project Manager		2.65	-	-	-	-	-	-	-	-	524
Faride Abzade	Construction Management Specialist		2.65	-	-	-	-	-	-	-	-	-
Jennifer Minton	Project Manager		2.65	-	-	-	-	-	-	-	-	-
Jeremy Taylor	Program Manager		2.65	1,991	-	-	-	-	-	-	-	-
Jill Chomycia	Permitting Coordinator		2.65	-	-	-	1,991	-	-	-	-	-
John Uhrin	Sr. Cost Estimator		2.65	-	-	-	-	-	-	-	1,991	-
Kristina McLean	Construction Management Specialist		2.65	-	-	-	-	-	-	-	-	-
Matthew Gribbins	Project Manager		2.65	-	-	-	-	-	-	-	-	-
Meredith Jordan	Permitting Specialist		2.65	-	-	-	1,991	-	-	-	-	-
Reed Featherstone	Construction Management Specialist		2.65	-	-	-	-	-	-	-	-	-
Rich Edwards	Scheduler		2.65	-	1,991	-	-	-	-	-	-	-
Robert McCaig	Construction Management Specialist		2.65	-	-	-	-	-	-	-	-	-
Scott Gibson	Design Manager		2.65	-	-	-	-	-	-	1,991	-	-
TBD Construction Management Specialist 04	Construction Management Specialist		2.65	-	-	-	-	-	-	-	-	-
Virginia Anderson	Administrative Assistant		2.65	1,991	-	-	-	-	-	-	-	-
Zach Barbarick	Construction Management Specialist		2.65	-	-	-	-	-	-	-	-	-
Milton Stamp	Safety		2.51	-	-	-	-	-	-	-	1,991	-
Bill Van Derveer	Program Delivery (SME)		2.82	314	-	-	-	-	-	-	-	-
Emma Gentry	Technical Editor		2.82	210	-	-	-	-	-	-	-	-
Eric Biederman	Administrative Support		2.82	210	-	-	-	-	-	-	-	-
Eric Hjelle	Schedule Support		2.82	-	314	-	-	-	-	-	-	-
Eric Ward	Project Manager		2.82	-	-	-	-	-	-	-	-	-
Jason Rozgony	Sr. Cost Estimator		2.82	-	-	-	-	-	-	-	105	-
Jude Grounds	RWF/WTP Technical Advisor		2.82	-	-	-	-	-	-	105	-	-
Kieran Christie	Schedule Support		2.82	-	314	-	-	-	-	-	-	-
Ligia Bejarano	Administrative Assistant		2.82	210	-	-	-	-	-	-	-	-
Mike Jesionowski	Sr. Cost Estimator		2.82	-	-	-	-	-	-	-	105	-
Mike Warriner	Constructability/Schedules		2.82	-	-	-	-	-	-	-	419	-
Russell Snow	Design Manager Pipelines and Reservoirs		2.82	-	-	-	-	-	-	314	-	-
Tammy Cleys	Project Manager		2.82	-	-	-	-	-	-	-	-	-
TBD Subject Matter Experts (Various)	Subject Matter Experts (SME)		2.82	-	-	-	-	-	-	157	891	-
TBD Technical Staff (Various)	Technical Resources		2.82	-	1,048	-	-	-	-	52	891	-
Tim Tekippe	Testing and Commissioning Lead		2.82	-	-	-	-	-	-	-	-	524
Wes Silva	Construction Manager		2.82	-	-	-	-	-	-	-	-	-
Grand Total				6,917	8,227	1,415	3,982	1,991	1,991	2,620	12,366	1,048

¹ Direct Labor Rates for TBD resources shall be submitted for approval on a case-by-case basis.

² approximately 15-20% overtime budget for Field Inspectors

Table 3.1. Estimated Fees for Planned Program Management Support Summary – Fiscal Year 2022-2023 (July 1, 2022 through June 30, 2023).

Name	Role	Current Billing Rate	Current Factor	Total
Andre Tolme	Program Construction Manager	2.65	\$	493,581
Brendan Robless	Project Manager	2.65	\$	414,219
Brittney Oseth	Controls Specialist	2.65	\$	139,515
Chad Carlson	Safety	2.65	\$	372,059
Dan Peterson	Controls Specialist	2.65	\$	174,658
David Marciniak	Public Affairs/Outreach	2.65	\$	316,548
Doug Shermack	Procurement and Contracts Administrator	2.65	\$	226,897
Elena Thomsen	Staff Professional	2.65	\$	119,675
Elena Thomsen	Construction Management Specialist	2.65	\$	119,675
Ellen Peterman	Controls Manager	2.65	\$	304,464
Elnaz Adeh	Special Projects Manager	2.65	\$	305,889
Eric Fullan	Safety	2.65	\$	279,084
Erika Murphy	Project Manager	2.65	\$	342,931
Faride Abzade	Construction Management Specialist	2.65	\$	216,608
Jennifer Minton	Project Manager	2.65	\$	350,477
Jeremy Taylor	Program Manager	2.65	\$	496,641
Jill Chomycia	Permitting Coordinator	2.65	\$	388,575
John Uhrin	Sr. Cost Estimator	2.65	\$	304,464
Kristina McLean	Construction Management Specialist	2.65	\$	259,454
Matthew Gribbins	Project Manager	2.65	\$	519,753
Meredith Jordan	Permitting Specialist	2.65	\$	202,783
Reed Featherstone	Construction Management Specialist	2.65	\$	162,363
Rich Edwards	Scheduler	2.65	\$	338,446
Robert McCaig	Construction Management Specialist	2.65	\$	182,679
Scott Gibson	Design Manager	2.65	\$	480,547
TBD Construction Management Specialist 04	Construction Management Specialist	2.65	\$	263,834
Virginia Anderson	Administrative Assistant	2.65	\$	235,129
Zach Barbarick	Construction Management Specialist	2.65	\$	169,381
Aldridge Lim	Field Inspector	2.51	\$	239,205
Bennie Bitz	Field Inspector	2.51	\$	353,537
Bill Kistner	Field Inspector	2.51	\$	341,857
Casey Kendall	Field Inspector	2.51	\$	305,254
Doug Kelley	Construction Manager	2.51	\$	449,762
Gabriel Jalbert	Construction Manager	2.51	\$	359,600
Grant Schoepper	Construction Manager	2.51	\$	324,306
Jerome Duletzke	Construction Manager	2.51	\$	415,426
John Nielsen	Construction Manager	2.51	\$	327,963
Kristina Tubbert	Field Administrative Assistant	2.51	\$	119,500
Kyle Butler	Construction Manager	2.51	\$	239,857
Larry Hodgson	Field Inspector	2.51	\$	366,163
Marc Krekos	Field Inspector	2.51	\$	387,628
Matt Nussbaumer	Field Inspector	2.51	\$	61,641
Matt Pease	Construction Manager	2.51	\$	336,409
Milton Stamp	Safety	2.51	\$	300,325
Modena Moore	Field Inspector	2.51	\$	334,597
Rick Hyatt	Field Inspector	2.51	\$	368,372
Rod Warner	Construction Manager	2.51	\$	368,396
Stephen Poage	Construction Manager	2.51	\$	184,195
Steve Clapper	Construction Manager	2.51	\$	288,829
TBD Field Inspector 07	Field Inspector	2.51	\$	315,176
TBD Field Inspector 08	Field Inspector	2.51	\$	348,428
TBD Field Inspector 10	Field Inspector	2.51	\$	242,466
TBD Field Inspector 11	Field Inspector	2.51	\$	221,201
TBD Field Inspector 12	Field Inspector	2.51	\$	348,428
TBD Field Inspector 13	Field Inspector	2.51	\$	378,789
TBD Field Inspector 14	Field Inspector	2.51	\$	363,006
TBD Field Inspector 15	Field Inspector	2.51	\$	363,006
TBD Field Inspector 16	Field Inspector	2.51	\$	378,789
TBD Field Inspector 17	Field Inspector	2.51	\$	242,466
TBD Field Inspector 18	Field Inspector	2.51	\$	253,008
TBD Field Inspector 19	Field Inspector	2.51	\$	378,789
TBD Field Inspector 20	Field Inspector	2.51	\$	315,176
TBD Field Inspector 21	Field Inspector	2.51	\$	378,789
TBD Field Inspector 22	Field Inspector	2.51	\$	363,006
TBD Field Inspector 23	Field Inspector	2.51	\$	190,840
TBD Field Inspector 24	Field Inspector	2.51	\$	283,369
TBD Field Inspector 25	Field Inspector	2.51	\$	189,395
TBD Field Inspector 26	Field Inspector	2.51	\$	302,043
Todd Tubbert	Construction Manager	2.51	\$	362,599
Tyler Butler	Construction Manager	2.51	\$	232,103
Bill Van Derveer	Program Delivery (SME)	2.82	\$	115,605
Emma Gentry	Technical Editor	2.82	\$	25,653
Eric Biederman	Administrative Support	2.82	\$	18,914
Eric Hjelle	Schedule Support	2.82	\$	69,457
Eric Ward	Project Manager	2.82	\$	211,663
Jason Rozgony	Sr. Cost Estimator	2.82	\$	27,115
Jude Grounds	RWF/WTP Technical Advisor	2.82	\$	27,175
Kieran Christie	Schedule Support	2.82	\$	42,025
Ligia Bejarano	Administrative Assistant	2.82	\$	18,323
Mike Jesionowski	Sr. Cost Estimator	2.82	\$	23,483
Mike Warriner	Constructability/Schedules	2.82	\$	122,636
Russell Snow	Design Manager Pipelines and Reservoirs	2.82	\$	108,698
Tammy Cleys	Project Manager	2.82	\$	150,035
TBD Subject Matter Experts (Various)	Subject Matter Experts (SME)	2.82	\$	259,998
TBD Technical Staff (Various)	Technical Resources	2.82	\$	261,527
Tim Tekippe	Testing and Commissioning Lead	2.82	\$	120,091
Wes Silva	Construction Manager	2.82	\$	156,865
	Other Direct Cost ³	1.00	\$	932,584
	Estimated 2023 Annual Labor Rate Adjustment ⁴	1.00	\$	451,300
Grand Total				\$ 24,247,175

¹ Direct Labor Rates for TBD resources shall be submitted for approval on a case-by-case basis.

² approximately 15-20% overtime budget for Field Inspectors

³ Other Direct Cost are estimated at 4% of direct labor cost

⁴ Estimated Aggregate Labor Rate Adjustment shall be used for annual cost of living and merit increase

Table 3.2. Estimated Fees for Planned Program Management Support for System wide Tasks – Fiscal Year 2022-2023 (July 1, 2022 through June 30, 2023).

Name	Role	Current Billing Rate	Current Factor	Program Management	Controls	WIFIA	Permitting	Procurement	Public Outreach	Design Management	SW Construction Management	Facilities Commissioning & Startup
				PROG_1.0	PROG_1.0	PROG_1.0	PROG_1.0	PROG_1.0	PROG_1.0	PROG_1.0	PROG_1.0	PROG_1.0
Andre Tolme	Program Construction Manager		2.65	\$ -	\$ -	\$ -	\$ -	\$ -	\$ -	\$ -	\$ 493,581	\$ -
Brendan Robless	Project Manager		2.65	\$ -	\$ -	\$ -	\$ -	\$ -	\$ -	\$ -	\$ -	\$ -
Brittney Oseth	Controls Specialist		2.65	\$ -	\$ 69,758	\$ 69,758	\$ -	\$ -	\$ -	\$ -	\$ -	\$ -
Chad Carlson	Safety		2.65	\$ -	\$ -	\$ -	\$ -	\$ -	\$ -	\$ -	\$ 372,059	\$ -
Dan Peterson	Controls Specialist		2.65	\$ -	\$ 174,658	\$ -	\$ -	\$ -	\$ -	\$ -	\$ -	\$ -
David Marciniak	Public Affairs/Outreach		2.65	\$ -	\$ -	\$ -	\$ -	\$ -	\$ 316,548	\$ -	\$ -	\$ -
Doug Shermack	Procurement and Contracts Administrator		2.65	\$ -	\$ -	\$ -	\$ -	\$ 226,897	\$ -	\$ -	\$ -	\$ -
Elena Thomsen	Staff Professional		2.65	\$ -	\$ -	\$ -	\$ -	\$ -	\$ -	\$ -	\$ -	\$ -
Elena Thomsen	Construction Management Specialist		2.65	\$ -	\$ -	\$ -	\$ -	\$ -	\$ -	\$ -	\$ -	\$ -
Ellen Peterman	Controls Manager		2.65	\$ -	\$ 240,367	\$ 64,098	\$ -	\$ -	\$ -	\$ -	\$ -	\$ -
Elnaz Adeh	Special Projects Manager		2.65	\$ 305,889	\$ -	\$ -	\$ -	\$ -	\$ -	\$ -	\$ -	\$ -
Eric Fullan	Safety		2.65	\$ -	\$ -	\$ -	\$ -	\$ -	\$ -	\$ -	\$ 279,084	\$ -
Erika Murphy	Project Manager		2.65	\$ -	\$ -	\$ -	\$ -	\$ -	\$ -	\$ -	\$ -	\$ 90,245
Faride Abzade	Construction Management Specialist		2.65	\$ -	\$ -	\$ -	\$ -	\$ -	\$ -	\$ -	\$ -	\$ -
Jennifer Minton	Project Manager		2.65	\$ -	\$ -	\$ -	\$ -	\$ -	\$ -	\$ -	\$ -	\$ -
Jeremy Taylor	Program Manager		2.65	\$ 496,641	\$ -	\$ -	\$ -	\$ -	\$ -	\$ -	\$ -	\$ -
Jill Chomycia	Permitting Coordinator		2.65	\$ -	\$ -	\$ -	\$ 388,575	\$ -	\$ -	\$ -	\$ -	\$ -
John Uhrin	Sr. Cost Estimator		2.65	\$ -	\$ -	\$ -	\$ -	\$ -	\$ -	\$ -	\$ 304,464	\$ -
Kristina McLean	Construction Management Specialist		2.65	\$ -	\$ -	\$ -	\$ -	\$ -	\$ -	\$ -	\$ -	\$ -
Matthew Gribbins	Project Manager		2.65	\$ -	\$ -	\$ -	\$ -	\$ -	\$ -	\$ -	\$ -	\$ -
Meredith Jordan	Permitting Specialist		2.65	\$ -	\$ -	\$ -	\$ 202,783	\$ -	\$ -	\$ -	\$ -	\$ -
Reed Featherstone	Construction Management Specialist		2.65	\$ -	\$ -	\$ -	\$ -	\$ -	\$ -	\$ -	\$ -	\$ -
Rich Edwards	Scheduler		2.65	\$ -	\$ 338,446	\$ -	\$ -	\$ -	\$ -	\$ -	\$ -	\$ -
Robert McCaig	Construction Management Specialist		2.65	\$ -	\$ -	\$ -	\$ -	\$ -	\$ -	\$ -	\$ -	\$ -
Scott Gibson	Design Manager		2.65	\$ -	\$ -	\$ -	\$ -	\$ -	\$ -	\$ 480,547	\$ -	\$ -
TBD Construction Management Specialist 04	Construction Management Specialist		2.65	\$ -	\$ -	\$ -	\$ -	\$ -	\$ -	\$ -	\$ -	\$ -
Virginia Anderson	Administrative Assistant		2.65	\$ 235,129	\$ -	\$ -	\$ -	\$ -	\$ -	\$ -	\$ -	\$ -
Zach Barbarick	Construction Management Specialist		2.65	\$ -	\$ -	\$ -	\$ -	\$ -	\$ -	\$ -	\$ -	\$ -
Milton Stamp	Safety		2.51	\$ -	\$ -	\$ -	\$ -	\$ -	\$ -	\$ -	\$ 300,325	\$ -
Bill Van Derveer	Program Delivery (SME)		2.82	\$ 115,605	\$ -	\$ -	\$ -	\$ -	\$ -	\$ -	\$ -	\$ -
Emma Gentry	Technical Editor		2.82	\$ 25,653	\$ -	\$ -	\$ -	\$ -	\$ -	\$ -	\$ -	\$ -
Eric Biederman	Administrative Support		2.82	\$ 18,914	\$ -	\$ -	\$ -	\$ -	\$ -	\$ -	\$ -	\$ -
Eric Hjelle	Schedule Support		2.82	\$ -	\$ 69,457	\$ -	\$ -	\$ -	\$ -	\$ -	\$ -	\$ -
Eric Ward	Project Manager		2.82	\$ -	\$ -	\$ -	\$ -	\$ -	\$ -	\$ -	\$ -	\$ -
Jason Rozgony	Sr. Cost Estimator		2.82	\$ -	\$ -	\$ -	\$ -	\$ -	\$ -	\$ -	\$ 27,115	\$ -
Jude Grounds	RWF/WTP Technical Advisor		2.82	\$ -	\$ -	\$ -	\$ -	\$ -	\$ -	\$ 27,175	\$ -	\$ -
Kieran Christie	Schedule Support		2.82	\$ -	\$ 42,025	\$ -	\$ -	\$ -	\$ -	\$ -	\$ -	\$ -
Ligia Bejarano	Administrative Assistant		2.82	\$ 18,323	\$ -	\$ -	\$ -	\$ -	\$ -	\$ -	\$ -	\$ -
Mike Jesionowski	Sr. Cost Estimator		2.82	\$ -	\$ -	\$ -	\$ -	\$ -	\$ -	\$ -	\$ 23,483	\$ -
Mike Warriner	Constructability/Schedules		2.82	\$ -	\$ -	\$ -	\$ -	\$ -	\$ -	\$ -	\$ 122,636	\$ -
Russell Snow	Design Manager Pipelines and Reservoirs		2.82	\$ -	\$ -	\$ -	\$ -	\$ -	\$ -	\$ 108,698	\$ -	\$ -
Tammy Cleys	Project Manager		2.82	\$ -	\$ -	\$ -	\$ -	\$ -	\$ -	\$ -	\$ -	\$ -
TBD Subject Matter Experts (Various)	Subject Matter Experts (SME)		2.82	\$ -	\$ -	\$ -	\$ -	\$ -	\$ -	\$ 39,000	\$ 220,998	\$ -
TBD Technical Staff (Various)	Technical Resources		2.82	\$ -	\$ 137,646	\$ -	\$ -	\$ -	\$ -	\$ 6,882	\$ 116,999	\$ -
Tim Tekippe	Testing and Commissioning Lead		2.82	\$ -	\$ -	\$ -	\$ -	\$ -	\$ -	\$ -	\$ -	\$ 120,091
Wes Silva	Construction Manager		2.82	\$ -	\$ -	\$ -	\$ -	\$ -	\$ -	\$ -	\$ -	\$ -
	Other Direct Cost ³		1.00	\$ 932,584	\$ -	\$ -	\$ -	\$ -	\$ -	\$ -	\$ -	\$ -
	Estimated 2023 Annual Labor Rate Adjustment ⁴		1.00	\$ 21,120	\$ 18,623	\$ 2,325	\$ 10,270	\$ 3,940	\$ 5,497	\$ 11,502	\$ 39,261	\$ 3,653
Grand Total				\$ 2,169,858	\$ 1,090,980	\$ 136,180	\$ 601,627	\$ 230,838	\$ 322,045	\$ 673,804	\$ 2,300,004	\$ 213,989

¹ Direct Labor Rates for TBD resources shall be submitted for approval on a case-by-case basis.

² approximately 15-20% overtime budget for Field Inspectors

³ Other Direct Cost are estimated at 4% of direct labor cost

⁴ Estimated Aggregate Labor Rate Adjustment shall be used for annual cost of living and merit increase

Attachment 1. Fiscal Year 2022-2023 WWSP Master Program Schedule and Budget Baseline 7.0 including approved changes through March 31, 2022.

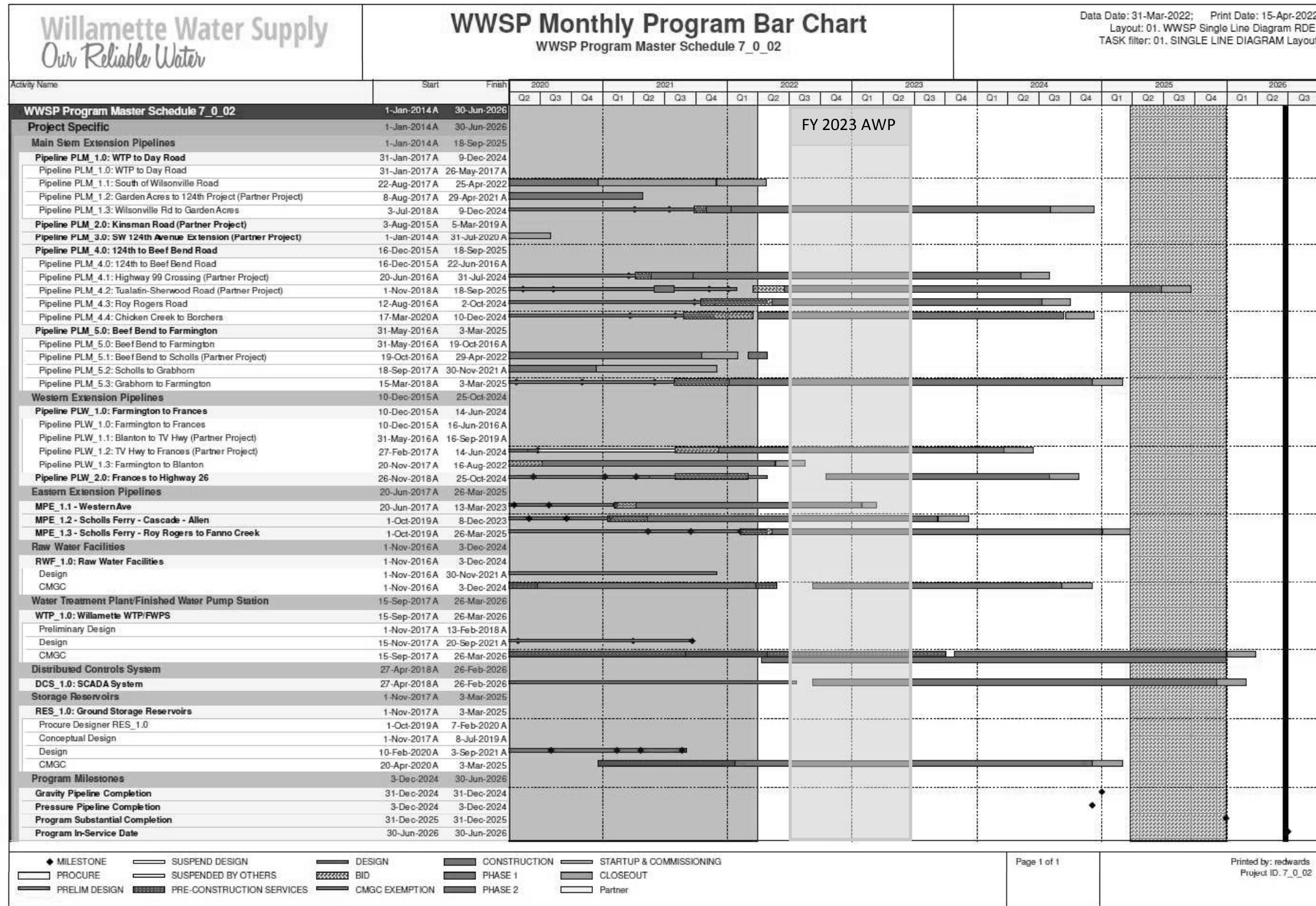

Willamette Water Supply System Commission

(this page intentionally left blank)

Willamette Water Supply Our Reliable Water

4.B. Approve Stantec Annual Work Plan for FY2023 Program and Construction Management Services

— Dave Kraska

WWSS Commission Board Meeting
June 2, 2022

1

The FY2023 AWP and Budget based on a “slice” of Baseline 7.0

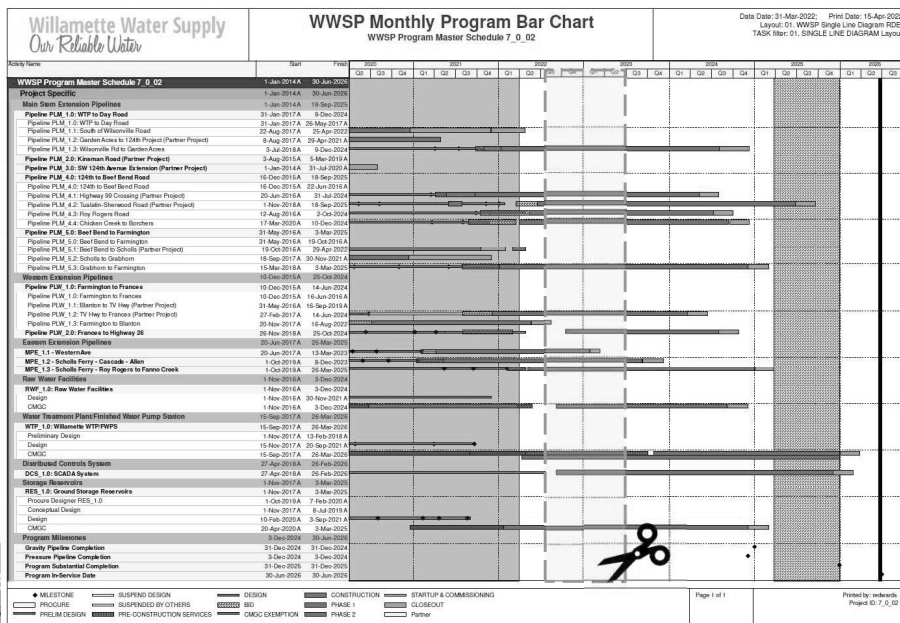

2

Program Work Planned for FY2023

- Advance 15 construction projects
- Continue program management
 - WIFIA compliance and loan programs
 - Safety program
 - Communications and outreach program
- Continued acquisitions
 - Real estate
 - Permits and land use approvals
 - Procurement
- Plan
 - Water supply integration
 - Commissioning and start-up
 - Operations

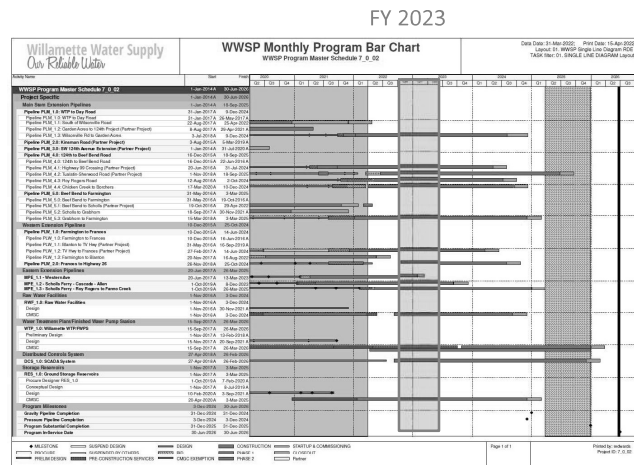

3

Stantec services originally procured in 2015

- 11.5-year term on the contract
- Cost was a key consideration in the initial selection of a program/construction management firm
 - The contract uses labor rate multipliers that do not change over the life of the WWSP
 - Annual labor rate adjustments are capped by the contract and are reviewed/approved by the Program Director
 - Staff proposed for WWSP work are reviewed and approved by the Program Director (considerations include: role, qualifications, labor rate, mobility costs)
- Annual Work Plan is negotiated each year based on anticipated activities

4

FY2023 AWP Budget

- \$24,247,175
- Refined down about \$500k from initial estimated budget
- Within Baseline 7.0
- About 6% of the total planned budget for next FY
 - Reduction from last year as construction spend increases
- About 36% increase in budget over last year
 - Major increase in construction activities requires significant expansion of staff (construction managers, inspectors, specialists)

5

Estimated Shares by WWSP Partner

Partners	Cost Shares
Beaverton	\$1,549,969
Hillsboro	\$7,763,134
TVWD	\$14,899,213
Other WIF Partners	\$34,859
Total	\$24,247,175

6

QUESTIONS?

7

4.B. Requested Board Action

Consider approving the Annual Work Plan with Stantec Consulting Services, Inc. to provide Program and Construction Management Services for the Willamette Water Supply Program during the Fiscal Year 2023.

8

STAFF REPORT

To: WWSS Board of Commissioners
From: Joelle Bennett, P.E., WWSP Assistant Program Director
Date: June 2, 2022
Subject: Anticipated Business Agenda Items for the July 2022 Meeting of the WWSS Board of Commissioners

Key Concepts:

The next Willamette Water Supply System (WWSS) Commission Board meeting agenda is anticipated to include staff recommendations for the following business agenda item:

1. PLW_2.1 Contract for Construction

Background:

There is one anticipated business agenda item for the July 7, 2022, meeting of the WWSS Board of Commissioners. Due to the dynamic nature of the WWSS work, request for approval of some items may be delayed or new items may emerge on the business agenda next month. WWSS staff strive to provide preliminary information one month prior to requesting action and a full staff report describing the recommended action during the appropriate month.

1. PLW_2.1 Contract for Construction

The PLW_2.1 project includes 3,300 linear feet of 48" welded steel water pipeline located within City of Hillsboro in the vicinity of Orenco Woods Nature Park. The WWSS is delivering the PLW_2.1 pipeline project utilizing a best value contracting approach. The request for proposals was published on April 6th and we received three responses. Price proposals were due May 10th and written proposals were due May 16th. The public bid opening is on June 7th.

At the next WWSS Board meeting, WWSP staff plan to present the proposed contract with a recommendation to the Board for approval.

Budget Impact:

Anticipated costs for the actions described in this staff report are reflected in the WWSP FY2023 budget.

Staff Contact Information:

Dave Kraska, P.E., WWSS General Manager, 503-941-4561, david.kraska@tvwd.org
Joelle Bennett, P.E., WWSP Assistant Director, 503-941-4577, joelle.bennett@tvwd.org

Attachments:

- Approvals and Procurement Forecast (May 2022 – July 2022)

Willamette Water Supply System Commission

(this page intentionally left blank)

Willamette Water Supply

Our Reliable Water

Approvals and Procurement Forecast: May 2022 through July 2022

This report provides a three-month projection of (1) forthcoming actions under the WWSS Management Authority Matrix and (2) ongoing and forthcoming procurements.

a = Actual date
 e = Email approval
 FC = Finance Committee
 LCRB = Local Contract Review Board
 MC = Management Committee
 N/A = Not applicable
 OC = Operations Committee

Rec. = Recommendation
 t = Tentative date
 TBD = To be determined; sufficient information not available to project a date
 Note: Dates in red text indicate meetings needed outside the normal meeting schedule

Type	Description	Projected Action	Body/Position (projected action date)		
			Program Director	WWSS Committees	WWSS Board
Program Baseline or Related Plans (above Program Director's Authority)	1. None	Approve	N/A	N/A	N/A
		Execute	N/A	N/A	N/A
Real Estate	2. None	Approve	N/A	N/A	N/A
IGAs, MOUs, Permit Commitments, & Similar Agreements	3. DCS_1.0 Sherwood Broadband Services IGA	Approve	N/A	MC: 3/18/2021 a	4/1/2021 a
		Execute	5/31/2022 t	N/A	N/A
	4. PLW_1.3 Butternut Creek Amendment 3	Approve	N/A	N/A	N/A
		Execute	5/31/2022 t	N/A	N/A
	5. Sherwood Emergency Intertie IGA	Approve	N/A	MC: 4/21/2022 a	5/5/2022 a
		Execute	6/30/2022 t	N/A	N/A
Contracts (above Program Director's Authority)	6. MPE_1.3 Contract for Construction <ul style="list-style-type: none"> Goal: Construct MPE_1.3 Value: \$49.2M Contractor: Emery & Sons Construction Group, LLC 	Approve	N/A	MC: 4/21/2022 a	5/5/2022 a
		Execute	5/6/2022 a	N/A	N/A
	7. PLW_2.1 Contract for Construction <ul style="list-style-type: none"> Goal: Construct PLW_2.1 Value: \$15.1M Contractor: TBD 	Approve	N/A	MC: 6/23/2022 t	7/7/2022 t
		Execute	7/8/2022 t	N/A	N/A
Contract Amendments and Change Orders (above Program Director's Authority)	8. Permitting Services Contract <ul style="list-style-type: none"> Goal: System-wide permitting Value: \$742,503.78 Contractor: DEA 	Approve	N/A	MC: 3/24/2022 a	4/7/2022 a
		Execute	5/31/2022 t	N/A	N/A
	9. RWF_1.0 GMP 1.5 for Construction <ul style="list-style-type: none"> Goal: Construct RWF_1.0 Value: \$3. M Contractor: Kiewit 	Approve	N/A	MC: 5/19/2022 t	6/2/2022 t
		Execute	6/3/2022t	N/A	N/A
Contract Amendments and Change Orders <i>continued</i> (above Program Director's Authority)	10. WWSP Program and Construction Management Services FY 2023 Annual Work Plan <ul style="list-style-type: none"> Goal: Approve scope, staffing, and fee for program and construction management services for FY 2023 Value: \$24.2 M 	Approve	N/A	MC: 5/19/2022 t	6/2/2022 t
		Execute	6/3/2022t	N/A	N/A

Willamette Water Supply

Our Reliable Water

Type	Description	Projected Action	Body/Position (projected action date)		
			Program Director	WWSS Committees	WWSS Board
Local Contract Review Board (LCRB) Actions	11. None	Approve	N/A	N/A	N/A

**Willamette Water Supply System Commission
Board Meeting**

June 2, 2022
