

**Willamette Water Supply System
Board Meeting Agenda
Thursday, December 5, 2019 | 12:00 – 2:00 PM**

**Tualatin Valley Water District – Board Room
1850 SW 170th Avenue, Beaverton, OR 97003**

To prepare to address the Willamette Water Supply System Board, please fill out the Public Comment Form located on the table near the main door to the meeting room. **Assistive Listening Devices (ALD) are available upon request 48 hours prior to the day of the meeting by calling (503) 941-4580.** All testimony is electronically recorded.

BOARD EXECUTIVE SESSION/LUNCH – 11:30 AM – TVWD Main Conference Room (MCR)

An executive session of the Board is called under ORS 192.660(2)(e) to conduct deliberations with persons designated by the governing body to negotiate real property transactions.

REGULAR SESSION – 12:00 PM

CALL TO ORDER

1. GENERAL MANAGER'S REPORT – Dave Kraska

(Brief presentation on current activities relative to the WWSS Commission)

2. PUBLIC COMMENT

(This time is set aside for persons wishing to address the Board on items on the Consent Agenda, as well as matters not on the agenda. Additional public comment will be invited on agenda items as they are presented. Each person is limited to five minutes, unless an extension is granted by the Board. Should three or more people testify on the same topic, each person will be limited to three minutes.)

3. CONSENT AGENDA

(The entire Consent Agenda is normally considered in a single motion. Any Commissioner may request that an item be removed for separate consideration.)

- A. Approve the November 7, 2019 meeting minutes.
- B. Approval to Execute Easement for PLM_5.2

4. BUSINESS AGENDA

- A. Approve Washington County Land Use and Transportation (WCLUT) Intergovernmental Agreements (IGA) Amendments – *Joelle Bennett*

- 1. WCLUT PLM_4.1 Design IGA Amendment 2
- 2. WCLUT PLM_4.2 Design IGA Amendment 1
- 3. WCLUT PLW_1.2 Design IGA Amendment 1

- B. Acting as Local Contract Review Board (LCRB):

- 1. Approve Clarification of Public Contracting Officer Role – *Dave Kraska*
- 2. Approve Public Notice of Intent to Approve Alternative Contracting Methods for Construction of Selected Pipeline Projects – *Dave Kraska/Bill Van Derveer*

5. INFORMATION ITEMS

- A. Planned January Business Agenda items – *Joelle Bennett*
- B. The next Board meeting is scheduled on January 9, 2020, at Tualatin Valley Water District – Board Room.

6. COMMUNICATIONS AND NON-AGENDA ITEMS

- A. None scheduled.

ADJOURNMENT



1



2

Safety on the Road:

- Plan trips carefully. Check the latest weather forecasts and road conditions. If bad weather is forecast, drive only if absolutely necessary.
- Keep an [emergency supply kit](#) in your car. You never know when you will encounter a traffic emergency or road closure.

3

BUILDING AN EMERGENCY SUPPLY KIT FOR YOUR CAR

WHY?
BECAUSE YOU NEVER KNOW WHEN YOU WILL ENCOUNTER WINTER WEATHER OR AN EMERGENCY ROAD CLOSURE.

AMERICA'S **PrepareAthon!**
BE SMART. TAKE PART. PREPARE.

- CELL PHONE, CHARGER
- FIRST AID KIT
- JUMPER CABLES
- TIRE CHAINS OR SNOW TIRES
- FLARES
- WATER, SNACKS
- FULL TANK OF GAS
- FLASHLIGHT
- BAG OF SAND OR CAT LITTER
- BOOTS, MITTENS, WARM CLOTHES
- BLANKET
- TOW ROPE
- SHOVEL, ICE SCRAPER, SNOW BRUSH

4



Willamette Water Supply System Commission

(this page intentionally left blank)

MEMO

Date: December 5, 2019

To: Willamette Water Supply System Board of Commissioners

From: David Kraska, P.E., General Manager

Re: Willamette Water Supply System (WWSS) General Manager's Report

The following items will be covered during the report by the General Manager (GM):

- 1. Be Sure to Use Microphones** – Please remember to use your microphone whenever you are speaking. Also, please turn off your microphone when you are not speaking.
- 2. Safety Minute** – David Kraska will present today's safety minute.
- 3. Approvals and Procurements Forecast** – Attached to this GM report is the approvals and procurements forecast for November through January. The forecast presents a view of WWSP activities that have recently been approved or are scheduled for approval over the next two months by either the WWSP Director, the WWSS Management Committee, or the WWSS Board.

Noteworthy in this forecast is that we are continuing our annual rebaseline effort to update our overall Program budget and schedule, targeting approval by the WWSS Board in March. Additionally, we expect the Master Project Coordination intergovernmental agreement (IGA) with Washington County, which this Board approved in November, to be approved by the County at its meeting on December 17.

- 4. Projects Planning, Permitting, and Communications Updates** – Various planning, permitting, and communications activities continued over the past month. On November 25, 2019, the City of Wilsonville Development Review Board (DRB) considered our land use application for the Raw Water Facilities (RWF) project. City staff and WWSP staff both made presentations to the DRB to provide background information on the RWF project and to explain our application. One resident whose property borders the project attended the meeting to ask questions regarding tree removal near her property. In the end, the DRB unanimously approved our application with a minor amendment to one of the conditions of approval. The conditions of approval are not unexpected or unreasonable.

GM Report to the WWSS Board of Commissioners

December 5, 2019

Page 2

- 5. Projects Design Status Updates** – Work continues on multiple design projects including nine pipeline projects, the RWF project, the Water Treatment Plant, and the Distributed Controls System. In response to our request for proposals for the reservoirs project (RES_1.0), we received responses from two design consultants: HDR and Black & Veatch. Both consultants are currently working on other WWSP projects. HDR is the design consultant for PLM_1.0, PLM_3.0, and the firm provides real estate consulting services. Black & Veatch is the design consultant for the RWF project. Both firms will be interviewed on December 11. This is the last major design consultant contract to be procured by the WWSP.

- 6. Projects Construction Status Updates** – There are four projects actively under construction:
 1. PLM_1.1 – our raw water pipeline project in Wilsonville that extends from our RWF project to Wilsonville Road,
 2. PLM_1.2 – another raw water pipeline project being completed in partnership with the City of Wilsonville’s Garden Acres Road project,
 3. PLM_5.1 – a finished water pipeline project being completed in partnership with Washington County’s Roy Rogers Road project, and
 4. PLM_5.2 – a finished water pipeline project along SW Scholls Ferry and SW Tile Flat roads that we are working to complete in advance of development work in the area.

All of these projects remain on track and are progressing according to plan. A portion of the PLM_5.2 project will be constructed in the existing SW Tile Flat Road right-of-way. Constructing this portion of the pipeline will require a shutdown of SW Tile Flat Road between Grabhorn Road and Scholls Ferry Road. To mitigate the anticipated traffic impacts, WWSP staff prepared a traffic control plan and detour route map that was recently approved by Washington County Land Use & Transportation. Washington County also approved our request to maintain this closure for up to 61 days.

Approvals and Procurement Forecast: November 2019 through January 2020

This report provides a three-month projection of (1) forthcoming actions under the WWSS Management Authority Matrix and (2) ongoing and forthcoming procurements.

a = Actual date
e = Email approval
FC = Finance Committee
LCRB = Local Contract Review Board
MC = Management Committee
N/A = Not applicable
OC = Operations Committee

Rec. = Recommendation
t = Tentative date
TBD = To be determined; sufficient information not available to project a date
Note: Dates in **red text** indicate meetings needed outside the normal meeting schedule

Type	Description	Projected Action	Body/Position (projected action date)		
			Program Director	WWSS Committees	WWSS Board
Program Baseline or Related Plans	1. WWSP Annual Rebaseline Schedule and Budget	Approve	N/A	MC: 2/20/2020 t FC & OC: 1/6-17/2020 e,t	3/5/2020 t
		Execute	N/A	N/A	N/A
Real Estate	2. PLM_5.2 Easement	Approve	N/A	MC: 11/19/2019 t	12/5/2019 t
		Execute	12/6/2019 t	N/A	N/A
	3. PLM_1.3 Resolution of Need	Approve	N/A	MC: 1/23/2020 t	2/6/2020 t
IGAs, MOUs, Permit Commitments, & Similar Agreements	4. MPE_1.0 City of Beaverton (COB_1.0) Project Agreement	Approve	N/A	N/A	8/21/2019 a (Via WWSS MC)
		Execute	Pending	N/A	N/A
	5. RWF_1.0 City of Wilsonville Project Agreement	Approve	N/A	MC: 10/16/2019 a	10/28/2019 a
		Execute	10/28/2019 a	N/A	N/A
	6. WCLUT Master Project Coordination IGA	Approve	N/A	MC: 10/16/2019 a	11/7/2019 a
		Execute	11/8/2019 a	N/A	N/A
	7. PLM_4.4 WCLUT Design IGA	Approve	N/A	MC: 10/16/2019 a	11/7/2019 a
		Execute	11/8/2019 a	N/A	N/A
	8. PLM_5.2 City of Tigard IGA Amendment	Approve	N/A	MC: 10/16/2019 a	11/7/2019 a
		Execute	12/18/2019 a	N/A	N/A
	9. PLW_1.3 Hagg Lane (Butternut Creek) Agreement Amendment	Approve	N/A	N/A	N/A
Execute		12/6/2019 t	N/A	N/A	
10. PLM_4.1 WCLUT Design IGA Amendment 2	Approve	N/A	MC: 10/16/2019 a	12/5/2019 t	
	Execute	12/6/2019 t	N/A	N/A	
11. PLM_4.2 WCLUT Design IGA Amendment 1	Approve	N/A	MC: 10/16/2019 a	12/5/2019 t	
	Execut3	12/6/2019 t	N/A	N/A	

Type	Description	Projected Action	Body/Position (projected action date)		
			Program Director	WWSS Committees	WWSS Commission Board
IGAs, MOUs, Permit Commitments, & Similar Agreements <i>continued</i>	12. PLM_5.1 WCLUT Construction IGA Amendment 1	Approve	N/A	MC: 10/16/2019 a	12/5/2019 t
		Execute	12/6/2019 t	N/A	N/A
	13. PLW_1.2 WCLUT Design IGA Amendment 1	Approve	N/A	MC: 10/16/2019 a	12/5/2019 t
		Execute	12/6/2019 t	N/A	N/A
Contracts	14. Pipeline Contractors Prequalification <ul style="list-style-type: none"> • Goal: Prequalify contractors for 48" - 66" pipeline installation contracts ➤ Publish Request for Qualifications: 9/30/2019 a • Receive Statements of Qualifications: 10/31/2019 a • Recommendation for Prequalification: 11/11/2019 a • Notice of Prequalification: 11/13/2019 a 	Approve	11/13/2019 a	N/A	N/A
		Execute	N/A	N/A	N/A
	15. RES_1.0 Design, Bidding, and Services During Construction <ul style="list-style-type: none"> • Goal: Designer for RES_1.0 • Approximate Value: \$6.1M • Engineer: TBD ➤ Publish Request for Proposals: 10/23/2019 a • Proposal Due Date: 11/21/2019 • Rec. of Award: 12/10/2019 e,t • Notice of Intent to Award: 12/11/2019 t • Notice to Proceed: 2/7/2020 t 	Approve	N/A	MC: 1/23/2020 t	2/6/2020 t
		Execute	2/7/2020 t	N/A	N/A
Contract Amendments and Change Orders (above Program Director's Authority)	16. MPE_1.0 Design Amendment for City of Beaverton Pipeline (COB_1.0) Addition <ul style="list-style-type: none"> • Goal: Amend contract for final design and services during construction to add COB_1.0 project in accordance with project agreement • Approximate value: \$1,558,884.40 • Contractor: Brown and Caldwell 	Approve	N/A	N/A	8/21/2019 a (Via WWSS MC)
		Execute	Pending	N/A	N/A
	17. Program Regulatory Permitting and Related Consulting Services <ul style="list-style-type: none"> • Goal: Amend contract to provide professional services from January 2020 through February 2021 • Approximate value: TBD • Contractor: David Evans and Associates, Inc. 	Approve	N/A	12/19/2019 t	1/9/2020 t
		Execute	1/15/2020 t	N/A	N/A
18. PLM_1.2 Construction Contract Change Order to add Day Road Crossing <ul style="list-style-type: none"> • Goal: Change order to Construction contract to add Day Road Crossing (Wilsonville Contract) • Value: TBD • Contractor: Moore Excavation 	Approve	N/A	MC: 1/23/2020 t	2/6/2020 t	
	Execute	2/7/2020 t (by Wilsonville)	N/A	N/A	
	19. WTP_1.0 Design amendment for scope modifications <ul style="list-style-type: none"> • Goal: Amend contract for design services related to additional engineering services • Value: TBD • Contractor: CDM Smith 	Approve	N/A	MC: 1/23/2020 t	2/6/2020 t
		Execute	2/7/2019 t	N/A	N/A

Type	Description	Projected Action	Body/Position (projected action date)		
			Program Director	WWSS Committees	WWSS Commission Board
Contract Amendments and Change Orders <i>continued</i> (above Program Director's Authority)	20. PLM_5.3 Design Amendment for Selected Alternative Delivering Schedule <ul style="list-style-type: none"> • Goal: Amend contract for final design and services during construction to reflect realignment; Create additional bid package • Value: TBD • Contractor: Jacobs 	Approve	N/A	MC: 1/23/2020 t	2/6/2020 t
		Execute	2/7/2019 t	N/A	N/A
Local Contract Review Board (LCRB) Actions	21. LCRB Role Clarification <ul style="list-style-type: none"> • Board approval item to clarify LCRB role of public contracting officer is fulfilled by the WWSS General Manager 	Approve	N/A	MC: 11/19/2019 t	12/5/2019 t (as LCRB)
		Execute	N/A	N/A	N/A
	22. Findings for the Use of Alternative Contracting Methods for Construction of Selected Pipeline Packages <ul style="list-style-type: none"> • Board action to initiate public comment period 12/5/2019 t 	Approve	N/A	MC: 11/19/2019 t	1/9/2020 t (as LCRB)
		Execute	N/A	N/A	N/A

Willamette Water Supply System Commission

(this page intentionally left blank)

**Willamette Water Supply System Commission
Board Meeting Minutes
Thursday, November 7, 2019**

Commissioners present:

Tualatin Valley Water District (TVWD): Jim Duggan
Hillsboro: David Judah (alternate)
Beaverton: Denny Doyle

Committee Members present:

TVWD: Tom Hickmann, Management Committee
Carrie Pak, Operations Committee
Hillsboro: Eric Hielema, Operations Committee
Beaverton: David Donaldson, Management Committee
David Winship, Operations Committee

Managing Agency Staff present:

Dave Kraska, Willamette Water Supply Program (WWSP) Director; WWSS Commission General Manager
Joelle Bennett, WWSP Assistant Director
Bill Van Derveer, WWSP Manager
Clark Balfour, TVWD General Counsel
Marlys Mock, WWSP Communications Supervisor
Christopher Bowers, TVWD Water Operations and Asset Management Administrative Assistant
Faye Branton, WWSP Administrative Assistant; WWSS Commission Recorder

Other Attendees:

No members of the public were present.

CALL TO ORDER

Chairman Duggan called the regular Willamette Water Supply System (WWSS) Commission meeting to order at 12:01 p.m.

1. GENERAL MANAGER'S REPORT

Mr. Kraska opened with a safety moment covering Safely Walking on Snow and Ice (*see presentation*), followed by the General Manager's report, which included an overview of the Approvals and Procurement Forecast; and updates on projects planning, permitting, and communications; design status of projects; and construction status of projects.

2. PUBLIC COMMENT

There were no public comments.

3. CONSENT AGENDA

- A. Approve the October 3, 2019 regular meeting minutes.
- B. Approve the October 28, 2019 special meeting minutes.

Motion was made by Judah seconded by Doyle to approve the consent agenda as presented. The motion passed unanimously with Doyle, Duggan, and Judah, voting in favor.

4. BUSINESS AGENDA

- A. Consider adopting Resolution No. WWSS-10-19, a resolution approving an Intergovernmental Agreement with Washington County Land Use and Transportation to serve as a Master Agreement for Project Coordination. – *Staff Report – Dave Kraska*

Mr. Kraska presented the staff report requesting the Board's adoption of Resolution WWSS-10-19.

In response to Commissioner's questions, staff confirmed that Washington County will pay what they normally would pay. The additional administrative costs related to WIFIA compliance tracking will be covered by WWSS.

Staff also clarified that the road restoration costs referred to in the IGA date back to the 2016 Memorandum of Understanding (MOU) with Washington County related to the PLM_4.4 pipeline project. Per agreement with Washington County, WWSS will help fund specific road restoration work by aligning other WWSP projects with the County's. It is critical that we define what those funds are and separate them from WIFIA costs.

Motion was made by Doyle seconded by Judah to adopt Resolution No. WWSS-10-19, a resolution approving an Intergovernmental Agreement with Washington County Land Use and Transportation to serve as a Master Agreement for Project Coordination. The motion passed unanimously with Doyle, Duggan, and Judah, voting in favor.

In response to Commissioner's comment, staff clarified that, by adoption of Resolution WWSS-10-19, the Commission is directing legal staff to finalize this IGA for execution by the WWSS General Manager. No substantive changes are expected.

- B. Consider adopting Resolution No. WWSS-11-19, a resolution approving an Intergovernmental Agreement with Washington County for the Joint Design of PLM_4.4 at Roy Rogers Road from SW Borchers Drive to Chicken Creek. – *Staff Report – Dave Kraska*

Mr. Kraska presented the staff report requesting the Board's adoption of Resolution WWSS-11-19.

Motion was made by Doyle seconded by Judah to adopt Resolution No. WWSS-11-19, a resolution approving an Intergovernmental Agreement with Washington County for the Joint Design of PLM_4.4 at Roy Rogers Road from SW Borchers Drive to Chicken Creek. The motion passed unanimously with Doyle, Duggan, and Judah, voting in favor.

- C. Consider adopting Resolution No. WWSS-12-19, a resolution approving an amended and restated Intergovernmental Agreement with the City of Tigard for temporary water supply.
– *Staff Report – Dave Kraska*

Mr. Kraska presented the staff report requesting the Board’s adoption of Resolution WWSS-12-19.

Motion was made by Judah seconded by Doyle to adopt Resolution No. WWSS-12-19, a resolution approving an amended and restated Intergovernmental Agreement with the City of Tigard for temporary water supply. The motion passed unanimously with Doyle, Duggan, and Judah, voting in favor.

5. INFORMATION ITEMS

- A. Washington County Land Use and Transportation (WCLUT) Intergovernmental Agreements (IGA) Amendment Updates – *Joelle Bennett*
 - 1. WCLUT PLM_4.1 Design IGA Amendment 2
 - 2. WCLUT PLM_4.2 Design IGA Amendment 1
 - 3. WCLUT PLM_5.1 Construction IGA Amendment 1
 - 4. WCLUT PLW_1.2 Design IGA Amendment 1

- B. Other Planned December Business Agenda items – *Joelle Bennett*

Ms. Bennett presented information on anticipated business agenda items for the December 5, 2019 WWSS Commission Board meeting, including highlights of multiple Intergovernmental Agreements (IGAs) with Washington County; Permitting Support contract amendment; and Local Contract Review Board (LCRB).

In response to Commissioner’s question, staff briefly highlighted a history of Oregon’s competitive bidding statute. Staff and Commissioners confirmed they have not seen a challenge to competitive bidding exemptions over the last fifteen years.

- C. The next Board meeting is scheduled on December 5, 2019, at Tualatin Valley Water District Board Room.

6. COMMUNICATIONS AND NON-AGENDA ITEMS

- A. None scheduled.

ADJOURNMENT

There being no further business, Chairman Duggan adjourned the meeting at 12:33 p.m.

James Duggan, Chair

Denny Doyle, Vice Chair

Willamette Water Supply System Commission

(this page intentionally left blank)



1



2

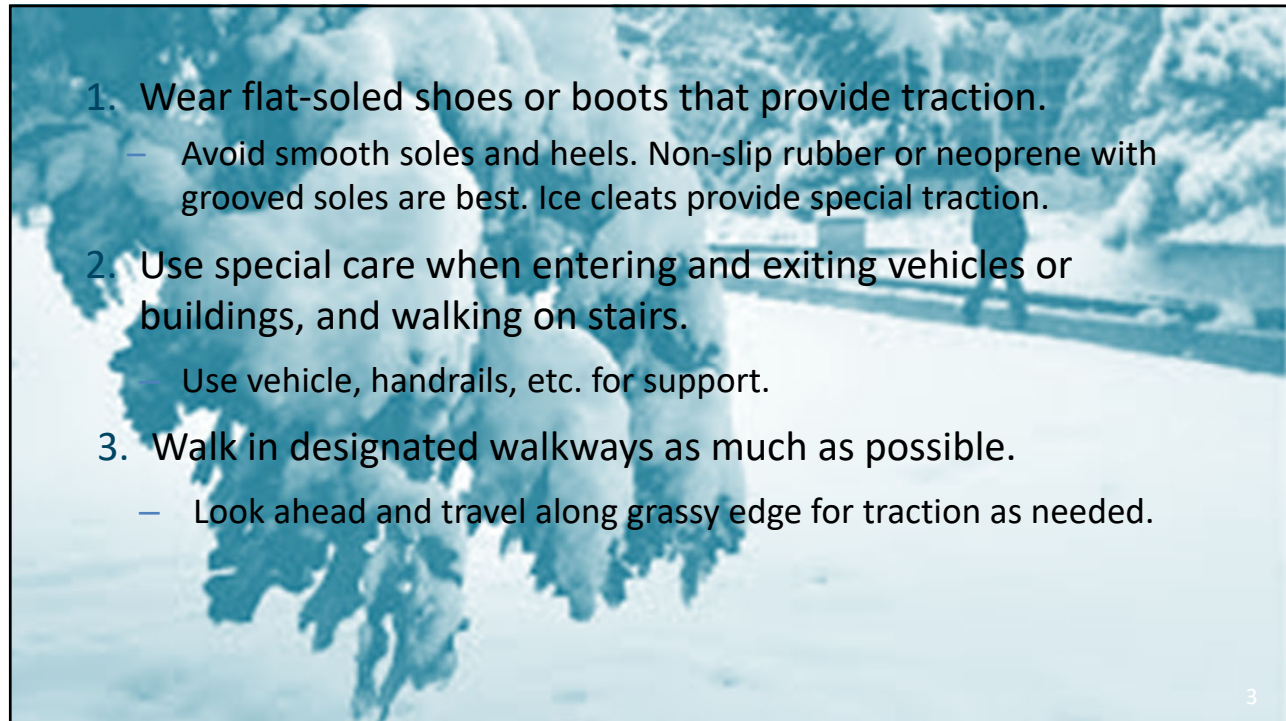

1. Wear flat-soled shoes or boots that provide traction.
 - Avoid smooth soles and heels. Non-slip rubber or neoprene with grooved soles are best. Ice cleats provide special traction.
2. Use special care when entering and exiting vehicles or buildings, and walking on stairs.
 - Use vehicle, handrails, etc. for support.
3. Walk in designated walkways as much as possible.
 - Look ahead and travel along grassy edge for traction as needed.

3

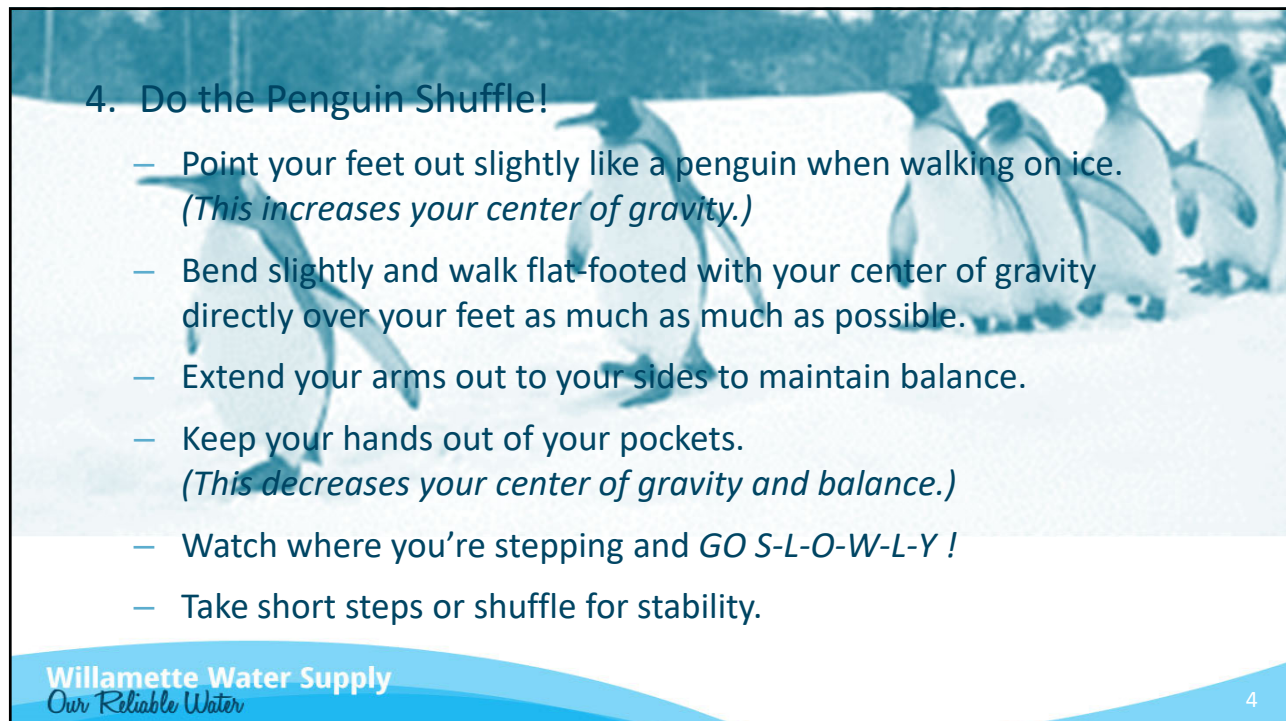

4. Do the Penguin Shuffle!
 - Point your feet out slightly like a penguin when walking on ice.
(This increases your center of gravity.)
 - Bend slightly and walk flat-footed with your center of gravity directly over your feet as much as possible.
 - Extend your arms out to your sides to maintain balance.
 - Keep your hands out of your pockets.
(This decreases your center of gravity and balance.)
 - Watch where you're stepping and *GO S-L-O-W-L-Y!*
 - Take short steps or shuffle for stability.

Willamette Water Supply
Our Reliable Water

4



5



6

Willamette Water Supply System Commission

(this page intentionally left blank)

STAFF REPORT

To: Willamette Water Supply System Board of Commissioners
From: David Kraska, P.E., Willamette Water Supply System General Manager
Date: December 5, 2019
Subject: Bartholemy Easement Acquisitions and Settlement Agreement for PLM_5.2

Requested Board Action:

Consider adopting a resolution approving and accepting the terms and conditions of a Water Systems Facilities Easement and authorizing execution of a Settlement Agreement between Ed Bartholemy and the Willamette Water Supply System (WWSS) for Parcel Number 2S106B00500

Key Concepts:

- PLM_5.2 is a portion of the WWSS transmission main in the City of Beaverton and Washington County from SW Roy Rogers Road along SW Scholls Ferry Road and SW Tile Flat Road to SW Grabhorn Road.
- Construction of PLM_5.2 is underway to enable completion prior to the developers' construction projects in the same general area.
- The Tualatin Valley Water District (TVWD), managing agency of the WWSS Commission, previously approved resolutions declaring public need and enabling acquisition of easements needed to construct PLM_5.2.
- The Board and Staff considered various alignments and alternatives and determined that the identified route was the best location for the water system facilities to be constructed and resulted in the least private injury to property owners.
- One of the parcels is owned by Ed Bartholemy. WWSS Staff and Mr. Bartholemy have reached agreement which requires WWSS Commission approval and acceptance of the Water System Facilities Easement and the Settlement Agreement for just compensation.
- Under the Settlement Agreement, the WWSS Commission will pay for just compensation for the Real Property Interests acquired and in full and final settlement of all matters, including but not limited to, land value and all claims and for payment of attorney fees, appraisal fees, witness fees and all other costs and disbursements arising out of the condemnation lawsuit known as Tualatin Valley Water District v. Ed Bartholemy, Washington County Circuit Court Case No. 19CV32796;

Background:

The pipeline route for PLM_5.2 includes the area on SW Scholls Ferry Road west of SW Roy Rogers Road, then north on SW Tile Flat Road to SW Grabhorn Road. It is located in both the City of Beaverton and unincorporated Washington County. It is approximately 9,911 feet of 66-inch diameter welded-steel pipe to convey finished drinking water from the Water Treatment Plant to the terminal storage reservoirs.

This pipeline alignment generally follows the current Right-of-Way (ROW) but requires easements to fulfill WWSS standard construction work zone requirements. Inside the City of Beaverton limits along SW Scholls Ferry Road and SW Tile Flat Road, much of the easement area is located in the planned residential

development area, and WWSS staff has coordinated with both the developers and the City of Beaverton to locate the pipeline in future road ROW. Securing additional easements on the remainder of the pipeline adjacent to future ROW is required to allow for reduced traffic disruption on these roads during construction by avoiding road closures to the maximum extent practicable. It also minimizes utility and pipeline conflicts and provides a wider work zone for pipeline installation.

The TVWD Board of Commissioners found that it was necessary to acquire permanent and temporary construction easement interests in the Bartholemy parcel identified above. TVWD, as the Managing Agency utilizing WWSP staff, retained real estate appraisers, negotiators, and other consultants to assist with negotiating with the affected property owners. A condemnation lawsuit was filed by TVWD known as Tualatin Valley Water District v. Ed Bartholemy, Washington County Circuit Court Case No. 19CV32796 (Litigation). Since that time the Willamette Water Supply Commission has been formed and it is the entity that will obtain ownership of the Real Property Interests. The parties have now come to an agreement on the terms and conditions of the Water System Facilities Easement, attached to the Resolution and an implementing Settlement Agreement. Staff requests that the Commission approve and accept the Water Systems Facilities Easement and authorize the General Manager to execute the Settlement Agreement as full and final resolution of all claims for compensation and attorney fees, appraisal fees and costs and disbursements (incurred by Bartholemy) as part of the transaction and the Litigation.

Budget Impact:

There are budgeted funds adequate for this acquisition and the Settlement Agreement.

Staff Contact Information:

David Kraska, P.E., Willamette Water Supply System General Manager; 503-941-4561;
david.kraska@tvwd.org

Joelle Bennett, P.E., Willamette Water Supply Program Assistant Program Director;
503-941-4577; joelle.bennett@tvwd.org

Attachments:

Proposed resolution

RESOLUTION NO. WWSS-13-19

A RESOLUTION ACCEPTING A WATER SYSTEM FACILITIES EASEMENT BETWEEN ED BARTHOLEMY AND THE WILLAMETTE WATER SUPPLY SYSTEM COMMISSION FOR WILLAMETTE WATER SUPPLY SYSTEM PROJECT PLM_5.2 (PARCEL 2S106B00500).

WHEREAS, the Willamette Water Supply System Commission (WWSS), an ORS intergovernmental entity formed under ORS Chapter 190, whose members are the Tualatin Valley Water District and the Cities of Hillsboro and Beaverton, is constructing the Willamette Water Supply System consisting of a Raw Water intake facility, Water Treatment Plant, terminal storage reservoirs and approximately 30 miles of large diameter pipelines to draw, treat and convey municipal waters to the members' water distribution systems, including the pipeline project known as PLM_5.2; and

WHEREAS, it is necessary for the WWSS to acquire certain permanent easements and temporary construction easements (Real Property Interests) from landowners along the route of PLM_5.2 and by previous resolutions, the TVWD Board of Commissioners has so declared; and

WHEREAS, the WWSS Staff and Ed Bartholemy have agreed to the terms of the Water System Facilities Easement for the Real Property Interests on the subject parcel granted by Ed Bartholemy attached hereto as Exhibit 1 and incorporated by reference, and a Settlement Agreement; and

WHEREAS, the Settlement Agreement provides for just compensation for the Real Property Interests acquired and in full and final settlement of all matters, including but not limited to land value and all claims and for payment of attorney fees, appraisal fees, witness fees and all other costs and disbursements arising out of the condemnation lawsuit known as Tualatin Valley Water District v. Ed Bartholemy, Washington County Circuit Court Case No. 19CV32796 (Litigation); and

WHEREAS, as the result of the intergovernmental agreement creating the WWSS Commission, the Commission is now the acquiring entity and needs to take action to accept the Water System Facilities Easement, attached hereto as Exhibit 1 and incorporated by reference, and, being advised,

NOW, THEREFORE, BE IT RESOLVED BY THE BOARD OF COMMISSIONERS OF THE WILLAMETTE WATER SUPPLY SYSTEM THAT:

Section 1: The Board of Commissioners approves the Water System Facilities Easement as set forth on Exhibit 1, attached hereto and incorporated by reference, accepting the terms and conditions thereof.

Section 2: The Board of Commissioners approves the terms of the Settlement Agreement as full and final satisfaction of all matters and claims arising out of this transaction and the referenced Litigation.

Section 3: The WWSS General Manager is authorized to sign all documents necessary to complete the conveyance of the Water System Facilities Easement and to implement the Settlement Agreement.

Approved and adopted at a regular meeting held on the 5th day of December 2019.

James Duggan, Chair

Denny Doyle, Vice Chair

Proposed

AFTER RECORDING RETURN TO:

Willamette Water Supply Commission
Attn: General Counsel
1850 SW 170th Avenue
Beaverton OR 97003

**UNTIL A CHANGE IS REQUESTED
SEND TAX STATEMENTS TO:**

No change in tax statements

File II: PLM 5.2-050
Map and Tax Lot: 2S106B000500

This space is reserved for recorder's use.

WATER SYSTEM FACILITIES EASEMENT

This Water System Facilities Easement is made this ____ day of _____, 2019, by and between Ed Bartholemy ("Grantor") and the Willamette Water Supply Commission, an ORS Chapter 190 intergovernmental entity consisting of the Tualatin Valley Water District, a domestic water supply district, organized under ORS Chapter 264, the City of Hillsboro, an Oregon municipal corporation and the City of Beaverton, an Oregon municipal corporation ("Grantee").

Grantor and Grantees agree as follows:

- 1. Grant of Permanent Easement.** The consideration consists of other property or value that is the whole consideration. Grantor hereby grants to Grantee its successors, assigns and heirs a perpetual and non-exclusive easement ("Easement") on, over, and under a portion of that certain real property located at 17811 SW Scholls Ferry Road, Beaverton, Washington County, Oregon, and identified as Tax Lot 2S106B000500 (the "Property"), which portion is described as Parcel 1 on Exhibit A and depicted as "Permanent Utility Easement Acquisition Area" on Exhibit B (the "Easement Area") Both exhibits are attached hereto and incorporated herein by this reference. The Easement shall be used by Grantee only for the purposes and as provided herein.

2. **Right of Entry and Use.** Subject to the terms of this Easement, Grantee shall have the right to enter upon and use the Easement Area for the purposes of constructing, operating, maintaining, repairing, replacing, and modifying water pipelines and other water facilities, and all appurtenances incident thereto ("Water System Facilities"). Within the Easement Area, Grantee shall have the perpetual right to cut, trim, control, and remove trees, brush, and other obstructions which injure or interfere with the Grantee's use or occupation of the Easement or Grantee's right to construct, reconstruct, install, use, operate, maintain, repair, patrol, replace, upgrade, or remove its improvements, without liability for damages arising there from. The use of the Easement by Grantee shall be in compliance with applicable laws.

3. **Temporary Easement.** During construction of the Water System Facilities, Grantor hereby grants a temporary construction easement ("TCE") on, over, and under that portion of the Property described as Parcel 2 on Exhibit A and depicted as "Temporary Construction Easement Acquisition Area" in Exhibit B (the "TCE Area"). The TCE granted pursuant to this Section shall terminate and expire on July 31, 2020 unless extended by the Parties in writing or pursuant to the Settlement Agreement between the Parties executed contemporaneously herewith.

4. **Restrictions on Grantees Use of Easement.**
 - a Grantee shall use good faith efforts to not interfere with Grantor's use and enjoyment of the Property outside the Easement Area or otherwise cause operations on Grantor's Property outside the Easement Area to be interfered with or interrupted by the use of the Easement by Grantee.

 - b Grantee shall maintain reasonable access to Grantor's property during construction, maintenance, repair, replacement, or modification of the Water System Facilities.

5. **Non-Exclusive Grant; Use of the Easement.** The Easement herein shall be non-exclusive for the purposes stated herein, and Grantor may not use the Easement Area inconsistent with the terms of this easement or permit third parties to use any portion of the Easement Area inconsistent with the terms of this easement without the Grantees' prior written approval, which shall not be unreasonably withheld, delayed or conditioned, provided:
 - a) The Grantor or approved third party shall provide a written request to the Grantee to use the Easement Area so that the Grantees' right to construct, use, access, repair, and maintain the Water System Facilities is not impaired; and

- b) The Grantor or approved third party assumes full responsibility in the event the Water System Facilities are damaged or impaired by their actions, in which case the Grantor or such third party shall immediately remedy the damage or impairment and indemnify Grantee from all expenses, costs, damages or impacts associated with such remedy. Grantee reserves the right to make necessary repairs or remedies with their own forces or contractors with the cost to be reimbursed by Grantor or third party; and
- c) All design and construction plans must comply with all applicable laws, rules and regulations and must be approved in writing by the Grantee in advance of construction, Grantee shall perform such reviews within 10 business days, and construction shall require Grantee's inspection and approval; and
- d) The Grantor or approved third party complies with Section 6.

6. **Grantor's Rights and Restrictions.**

- a) **Grantor's Rights.** Grantor shall retain the right to make full use of the Property outside the Easement Area provided that such use is compatible with the Grantee's use of the Easement Area.

“Compatibility” means that (a) Grantor shall only perform or permit other persons or entities to perform construction or other work within the Easement Area if such construction or other work is performed in accordance with all applicable laws, rules and regulations and (b) the construction or other work will not substantially interfere with the operation, maintenance, repair and replacement of the Water System Facilities.

Notwithstanding the provisions of Section 6.b. below, Grantor reserves use of the Easement Area, including installing driveways or roadways that are located at least five (5) feet above the Water System Facilities; fences and gates; for installation, operation, maintenance and repair of transportation facilities, including but not limited to sidewalks, curbs, and bicycle/pedestrian paths, and utilities, including but not limited to sewer, storm sewer and/or stormwater retention, electricity, natural gas, and telecommunications required by the City of Beaverton, Washington County, Clean Water Services, or the State of Oregon as a condition of approval for any development application submitted by Grantor or his successors and/or assigns seeking development approval of all or a portion of the Property, provided the transportation facilities and/or utilities are compatible with the Grantee's use of the Easement Area. Subject to Grantee's review of final design for compliance with Exhibit C, the parties agree that the siting by Grantor of sewer facilities in the Easement Area as described and depicted in Exhibit C to this easement is compatible as defined above with the Water

System Facilities. A copy of Exhibit C is attached to this easement and incorporated herein by this reference.

Prior to submitting a development application seeking approval for development that may affect Water System Facilities, Grantor will seek review and approval from Grantee of the proposed development that may affect Water System Facilities to determine compatibility. Grantee shall review within 10 business days and either approve or provide written comment as to why the compatibility determination cannot be given. Thereupon, the Grantor and Grantee shall meet to resolve the issue within 10 business days. If not resolved, then the matter will be submitted to arbitration by a mutually agreed, Oregon licensed Professional Engineer for final determination. Such decision shall be rendered within 20 business days or such other time as Grantor and Grantee mutually agree.

The Parties agree that Grantee's prior review and approval of a development application submitted by Grantor or his successors and/or assigns under this subsection that includes installation, operation, maintenance of any facility listed herein within the Easement Area is sufficient to demonstrate that the proposed development is compatible with Grantees' use of the Easement Area. Grantee agrees that any above-ground Water System Facilities within the Easement Area shall be compatible with and shall not interfere with the installation, operation, maintenance and repair of any transportation facilities and/or utilities Grantor has reserved the right to construct under this Section. However, Grantor agrees that it shall not locate transportation and utility facilities or utility facilities that restrict access to and into existing water system facility surface appurtenances that are in place at the time Grantor proposes to construct, subject to Grantee's obligations to adjust Grantee's water system facility surface appurtenances pursuant to Section 7 of this agreement.

If Grantor does not seek review and approval by Grantee of any proposed development that may affect Water System Facilities, or if Grantee does not approve Grantor's plans in advance of a development application because such plans are not compatible, Grantee may object and remonstrate to Grantor's development application pending with any agency and seek all available remedies at law or in equity.

- b) **Restrictions on Grantor.** Except for the installation, operation, maintenance, and repair of the transportation facilities and utilities set forth in Section 6.a above and unless otherwise approved in advance in writing by the Grantee, Grantor agrees, within the Easement Area:

- i) Not to construct or permit others to use, construct, install, store, plant, change grade, or create any improvements, structures, impoundments, or stockpile any materials that in the sole opinion of Grantee will impair, injure, or interfere with, now or in the future, any of Grantee's rights in the Easement Area including, but not limited to, Grantee's rights of operation, maintenance, and reasonable access.
 - ii) Not to store any materials including hazardous materials, fuel, oil, and chemicals on, over, under, or in the Easement Area. Grantor agrees not to store personal property, including but not limited to, derelict personal property, refuse piles, vehicles, equipment, or machinery in the Easement Area.
 - iii) Except as may be required by the City of Beaverton, or other local government, not to plant trees within the Easement Area and to limit any plants requiring rooting depths or cultivation within the Easement Area to avoid any ground disturbance or excavation exceeding twenty-four (24) inches in depth. Grantor agrees not to obstruct access to Grantee's above-ground Water System Facilities.
 - v) Not to change the grade within the Easement Area or drainage patterns within the Easement Area or adjacent to the Easement Area by adding, removing, or displacing any more than six (6) inches of material from the surface. Grantee agrees to provide as-built drawings showing existing grades for elevation reference purposes. Grantor also agrees not to impair any lateral or sub-adjacent support for the Water System Facilities within the Easement Area.
 - vi) Not to install or permit others to install within the Easement Area any utilities which require mechanical ground disturbance or excavation greater than twenty-four (24) inches deep.
 - vii) Not to place or permit others to place a load of any kind over the Water System Facilities where the weight of the load could cause damage of any type to the Water System Facilities.
 - viii) Not to impound water, change drainage patterns or create ponds, reservoirs, structures, or facilities designed to hold water over the Easement Area, unless the prior written consent of Grantee is provided.
- c) **Restoration of Easement.** At Grantee's sole cost and expense, and except where modifications to the Property are otherwise agreed to in this Agreement, Grantee shall restore said land as near as practicable to the same or better condition as existed in the Easement Areas as applicable

prior to the commencement of such work., All such restoration efforts shall comply with any applicable City, County, and State of Oregon codes.

7. **Scholls Ferry Road Expansion.** Should all or any portion of the Easement Area be within the future right-of-way of Scholls Ferry Road, Grantees shall bear the cost and obligation to adjust Grantees' infrastructure to remain compatible with the future grade of Scholls Ferry Road.
8. **Indemnification.**
 - a. Grantee: To the extent permitted by the Oregon Constitution and subject to the Oregon Tort Claims Act (ORS 30.260 to 30.300), Grantees shall indemnify and hold harmless Grantor and his employees, agents, representatives, successors and assigns (collectively, "Indemnified Parties") from and against any injury, expense, damage, liability, or claim, including, but not limited to, reasonable attorney fees, incurred by any Indemnified Party, arising directly or indirectly from Grantee's use of the Easement or any act or omission by Grantee or any Grantee's Party. Grantee assumes all risk arising out of their activities and use of the Easement by it and the Grantee's authorized agents.
 - b. Grantor: Grantor shall indemnify and hold harmless Grantee, its governing Board of Commissioners, employees, agents, contractors and consultants (collectively, "Indemnified Parties") from and against any injury, expense, damage, liability or claim, including, but not limited to, reasonable attorney fees incurred by any Indemnified Party, arising directly or indirectly from Grantor's use of the Easement or any act or omission by Grantor's use of the easement area or any act or omission by Grantor or any Grantor Party. Grantor assumes all risk arising out of his activities and use of the Easement area by Grantor or his authorized agents.
9. **Default and Remedies.** Time is of the essence regarding the terms of this Easement. If Grantor or Grantees violate any of the terms, covenants, or conditions of this Easement, or fails to perform any of its obligations included in this Easement in a timely manner, the non-defaulting Party shall have the right to declare a default by written notice and seek available legal or equitable remedies in the Circuit Court of the State for Oregon in Washington County. Notice shall be given by first class mail addressed to the parties as follows:

Ed Bartholemy
18485 SW Scholls Ferry
Road
Beaverton Or 97007

Willamette Water Supply
Commission
Attn: General Manager

1850 S.W. 170th Avenue

Beaverton, Oregon 97003

The notice shall provide a detailed statement(s) of the alleged default. If the default is not cured within 15 days from the date of notice, or if the defaulting Party has not commenced to diligently commence cure for a matter that requires more than 15 days, then the non-defaulting Party may commence litigation and seek all remedies available at law or in equity. If the Easement is terminated as a result of litigation, Grantee shall, at its sole cost and expense, return the Easement Area to Grantor in the same or better condition as existed prior to the grant of the Easement.

11. **Binding Effect.** This Easement is binding upon, inures to the benefit of and may be enforced by the Parties and their respective successors and assigns. Grantees may assign or transfer their interests without consent of Grantor. Grantee may use agents, employees, contractors, and other authorized persons for the purposes of exercising Grantees' rights and obligations under this Easement, provided no third-party beneficiary rights are created by this Easement. This Easement shall be construed in accordance with Oregon law.
12. **Amendment.** This Easement may be amended only by an instrument in writing signed by both Grantor and Grantee. All approvals required hereunder shall be in writing.
13. **No Public Dedication.** Nothing in this Easement will be deemed to be a gift or a dedication of any portion of the Water System Facilities Easement to the general public or for the use of the general public or for any public purpose whatsoever, it being the intent of the parties that this Easement be strictly limited to and for the purposes expressed herein.

[SPACE LEFT INTENTIONALLY BLANK]

[SIGNATURES TO FOLLOW]

GRANTOR

Ed Bartholemy

By: _____

Name: _____

Its: _____

GRANTEE

Willamette Water Supply System
Commission, an ORS Chapter 190 Entity

By: _____

Name: _____

Its: _____

[Acknowledgements follow on next page]

STATE OF OREGON)
) ss:
County of _____)

This instrument was acknowledged before me on _____, 20____,
by Ed Bartholemy.

NOTARY PUBLIC for Oregon
My commission expires: _____

STATE OF OREGON)
) ss:
County of Washington)

This instrument was acknowledged before me on _____, 20____,
by _____ as _____ of the Willamette Water
Supply Commission, an intergovernmental entity organized and operating under
ORS Chapter 190..

NOTARY PUBLIC for Oregon
My commission expires: _____

EXHIBIT A

Willamette Water Supply
November 25, 2019

Ed Bartholemy
Tax Map No. 2S106B 00500

PARCEL 1 – PERMANENT UTILITY EASEMENT

A parcel of land lying in the Section 6, Township 2 South, Range 1 West of the Willamette Meridian, Washington County, Oregon and being a portion of that property conveyed Ed Bartholemy, recorded October 21, 2014 as Document No. 2014-066989, in the Washington County Book of Records, said parcel being that portion of said property included in a strip of land variable in width, lying on the northerly side of, and all of that portion lying on the southerly side of, the following described Control Centerline:

Beginning at Centerline Station 807+72.00, said point being N 88°16'49" E, 3197.30 feet from the West 1 / 4 corner of Section 6, Township 2 South, Range 1 West of the Willamette Meridian; Thence along said centerline the following courses:
S 89°29'59" W, 189.70 feet to Station 809+61.70;
thence S 83°03'43" W, 100.59 feet to Station 810+62.29;
thence S 85°38'46" W, 147.71 feet to Station 812+10.00;
thence S 71°15'21" W, 55.55 feet to Station 812+65.55;
thence S 89°18'27" W, 1151.34 feet to Station 824+16.88;
thence N 45°57'23" W, 129.72 feet to Station 825+46.60;
thence S 88°46'47" W, 441.22 feet to Station 829+87.82;
thence S 89°29'07" W, 906.98 feet to Station 838+94.79;
thence S 85°10'41" W, 149.31 feet to Station 840+44.10, said point being N 19°22'34" W, 105.21 feet from said West 1 / 4 corner of Section 6;
thence continuing along said centerline S 79°51'57" W, 34.86 feet to Station 840+78.97;
thence S 76°09'13" W, 93.90 feet to Station 841+72.87;
thence S 71°04'33" W, 82.23 feet to Station 842+55.09;
thence S 68°42'19" W, 756.34 feet to Station 850+11.44;
thence S 69°44'05" W, 88.45 feet to Station 850+99.89;
thence N 68°25'58" W, 61.32 feet to Station 851+61.20;
thence N 32°20'49" W, 105.87 feet to Station 852+67.07;
thence N 30°20'05" W, 916.82 feet to Station 861+83.90;
thence N 29°58'27" W, 227.75 feet to Station 864+11.64;
thence N 74°58'27" W, 35.00 feet to Station 864+46.65;
thence N 29°58'27" W, 162.22 feet to Station 866+08.86;
thence N 33°01'07" W, 96.75 feet to Station 867+05.61;
thence N 8°01'36" E, 35.07 feet to Station 867+40.68;
thence N 38°22'58" W, 25.07 feet to Station 867+65.75;
thence N 39°09'05" W, 561.37 feet to Station 873+27.12;
thence N 40°04'53" W, 358.16 feet to a point of curvature at Station 876+85.28;
thence along the arc of a 5034.50 foot radius curve to the left with a central angle of 4°12'40" a curve distance of 370.02 feet (the chord of which bears N 42°11'13" W, 369.94 feet) to a point of tangency at Station 880+55.30 PT;
thence N 44°17'33" W, 144.60 feet to Station 881+99.90;
thence N 46°04'20" W, 126.52 feet to Station 883+26.42;

EXHIBIT A

**Willamette Water Supply
November 25, 2019**

**Ed Bartholemy
Tax Map No. 2S106B 00500**

thence N 49°38'24" W, 126.52 feet to Station 884+52.94;
thence N 51°25'11" W, 99.53 feet to Station 885+52.47;
thence N 57°45'20" W, 84.86 feet to Station 886+37.33;
thence N 70°25'37" W, 84.86 feet to Station 887+22.19; said point being N 51°41'57" W, 50.68 feet from the Northeast corner of the Solomon F. Shattuck D.L.C. number 51;
thence continuing along said centerline N 83°05'54" W, 84.86 feet to Station 888+07.05;
thence N 89°26'02" W, 1401.57 feet to Station 902+08.62;
thence N 44°26'02" W, 27.23 feet to Station 902+35.85;
thence N 0°55'28" E, 224.95 feet to Station 904+60.80;
thence N 25°53'14" W, 150.00 feet to Station 906+10.80;
thence N 0°55'28" E, 94.19 feet to Station 907+04.99 and the Terminus of said centerline description, said terminus also being N 2°51'50" W, 508.09 feet from the Southeast corner of the John Landess D.L.C. number 37.

The widths of the strip of land above referred to are as follows:

**CONTROL CENTERLINE
STATION**

WIDTH ON NORTHERLY SIDE OF CENTERLINE

From 822+28.36
To 827+50.00

118.00 feet in a straight line to 25.00 feet.

EXCEPT THEREFROM that portion lying within the right-of-way of SW Scholls Ferry Rd (CR 3278).

The parcel of land to which this description applies contains 18,240 square feet (0.42 acre), more or less.

Basis of Bearings is the Oregon Coordinate Reference System (OCRS), Portland Zone.

EXHIBIT A

**Willamette Water Supply
November 25, 2019**

**Ed Bartholemy
Tax Map No. 2S106B 00500**

PARCEL 2 – TEMPORARY CONSTRUCTION EASEMENT

That portion of said Bartholemy property included in a strip of land variable in width, lying on the northerly side of the Control Centerline described in Parcel 1:

The widths of the strip of land above referred to are as follows:

**CONTROL CENTERLINE
STATION**

WIDTH ON NORTHERLY SIDE OF CENTERLINE

From 821+53.36
To 823+53.36

179.00 feet.

From 823+53.36
To 827+50.00

142.74 feet in a straight line to 50.00 feet.

EXCEPT THEREFROM that portion lying within the right-of-way of SW Scholls Ferry Rd (CR 3278) and the above described Parcel 1.

The parcel of land to which this description applies contains 23,952 square feet (0.55 acre), more or less.



RENEWAL: 7/01/21
SIGNED: 11/25/2019

EXHIBIT B

TLID 2S106B000500
ED BARTHOLEMY
DOC No. 2014-066989

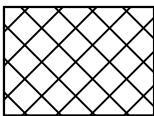
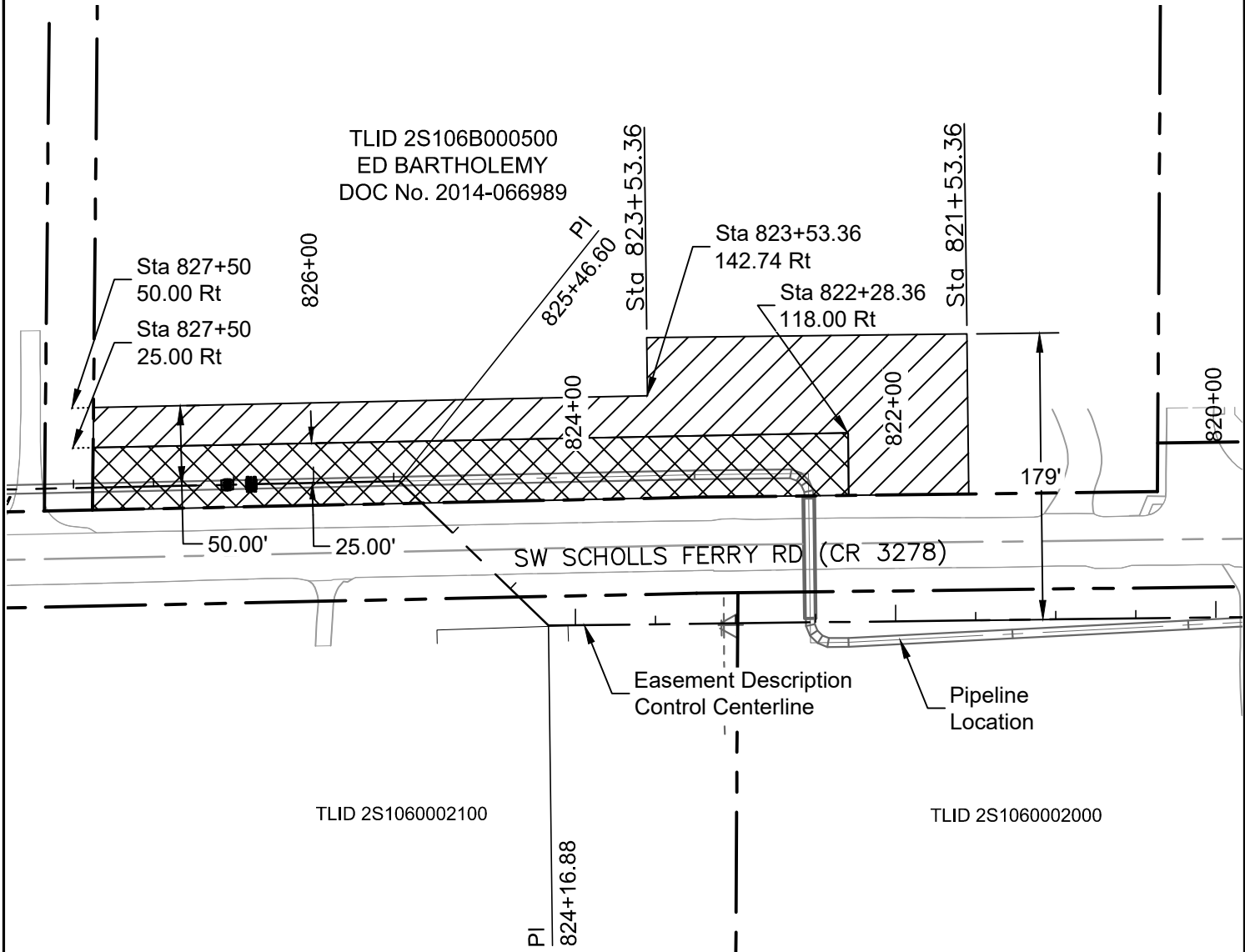

PARCEL 1 PERMANENT
UTILITY EASEMENT
ACQUISITION
AREA = 18,240 S.F.
(0.42 ac)

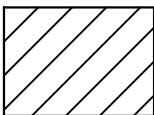

PARCEL 2 TEMPORARY
CONSTRUCTION EASEMENT
ACQUISITION
AREA = 23,952 S.F.
(0.55 ac)

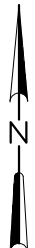

1"=100'

WILLAMETTE WATER SUPPLY PROGRAM

PIPELINE MAIN STEM, SECTION 5.2

FILE No:	SUBMITTAL DATE:
TAX LOT: 500	ADDRESS:
TAX MAP: T2S R1W Sec06B	

SUBMITTAL DATE:
ADDRESS:

ACQUISITION MAP

PAGE 1 OF 1



SURVEY & MAPPING

2020 SW 4TH AVE. SUITE 300 PORTLAND, OR 97201
PH: (503) 235-5000

HAACK PROPERTY SEWER LINE

SANITARY SEWER LINE EXTENSION IN SW SCHOLLS FERRY ROAD

APPLICANT/TOWNER

ED BARRINGTON
1848 SW SCHOLLS FERRY RD
BEAVERTON, OREGON 97007
CONTACT: DESMURTZ

ENGINEERING

PIEHLER DESIGN GROUP, INC.
6020 SW WASHINGTON SQ RD. STE 110
PORTLAND, OREGON 97224
PHONE: 503.644.8288
CONTACT: GEORGE KAWALAKO, PE

EXHIBIT C

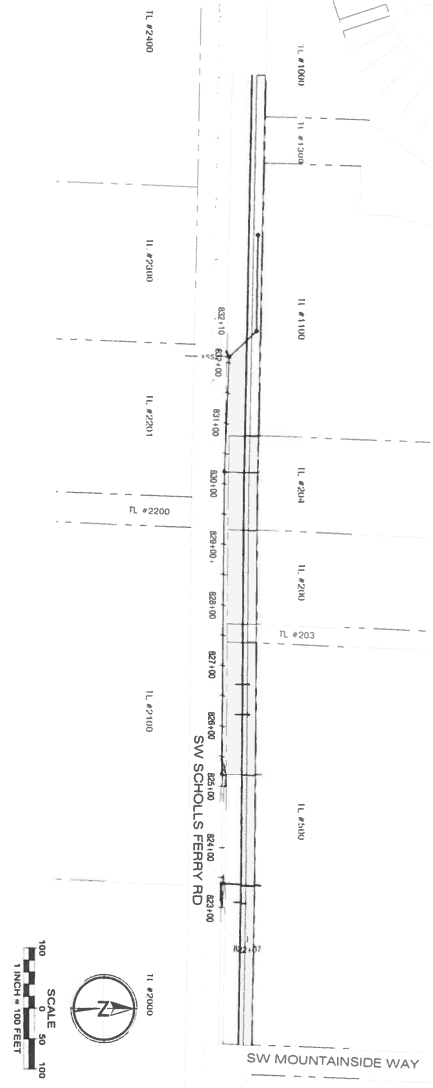

LOCATES (48 HOURS NOTICE REQUIRED)

LINE CALL SYSTEM
(GENERAL TELEPHONE, NORTHWEST
ELECTRIC, GAS, PORTLAND GENERAL
ELECTRIC)

REPAIR EMERGENCIES

HIGHWEST MATERIAL, GAS
PORTLAND GENERAL ELECTRIC
KEMZON
CONCAST
CLEANWATER SERVICES

800-488-1177
503-462-7156
503-482-1000
888-873-8264
503-481-2600
503-251-8100

THE CONTRACTOR IS LOCATING AND PROTECTING UNDERGROUND UTILITIES
WITH CARE, WITH THE RESOURCES OF GPS, SURVEYING TOOLS AND



SITE INFORMATION

SITE ADDRESS: 17811 SW SCHOLLS FERRY RD
TAX LOTS: 500
PERMITTED AREA: 0.09 ACRES (0.75 SQ FT)
SUBDIVISION: CITY OF BEAVERTON

VERTICAL DATUM

BEVINGHAM, WASHINGTON COUNTY B.M. 147 DATUM: NAVD 83
ELEVATION: 120.14 FEET
ONE SCHOLLS FERRY ROAD (SANDHURST) DISTRICT OFFICE OF SW 12811
ELEVATION: 382.58 FT

SHEET INDEX

- COVER SHEET
- CONTRACT SPECIFICATIONS & AMENDMENTS
- GENERAL NOTES
- SMALL SANITARY SEWER MAIN & PROPOSED
- CONNECTIONS TO EXISTING SANITARY SEWER MAIN
- CITY OF BEAVERTON & CIVIL ENGINEERING DIVISION
- CIVIL ENGINEER: GEORGE KAWALAKO, P.E.

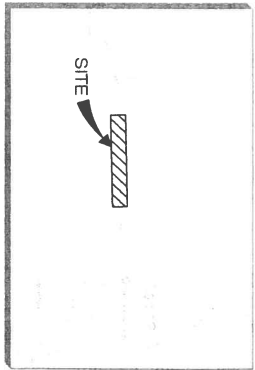

VICINITY MAP
N.T.S.

11/12/2019

COVER SHEET

HAACK PROPERTY
BEAVERTON, WASHINGTON COUNTY, OREGON



PIONEER DESIGN GROUP
CIVIL ENGINEERING • LAND USE PLANNING • LAND SURVEYING • LANDSCAPE ARCHITECTURE
PORTLAND, OREGON | HONOLULU, HAWAII
PH: 503.644.8288 | FAX: 503.651.2770
WWW.PD-GRP.COM

No.	Date	Revision	By	Designed by	DATE
1	10/06/2019	PER COS RED. LINES	GAM	GAM	08/25/2019

Project: HAACK PROPERTY
No.: 373-001
Title: EXHIBIT C-1
Sheet: CO.10

EXHIBIT C-1

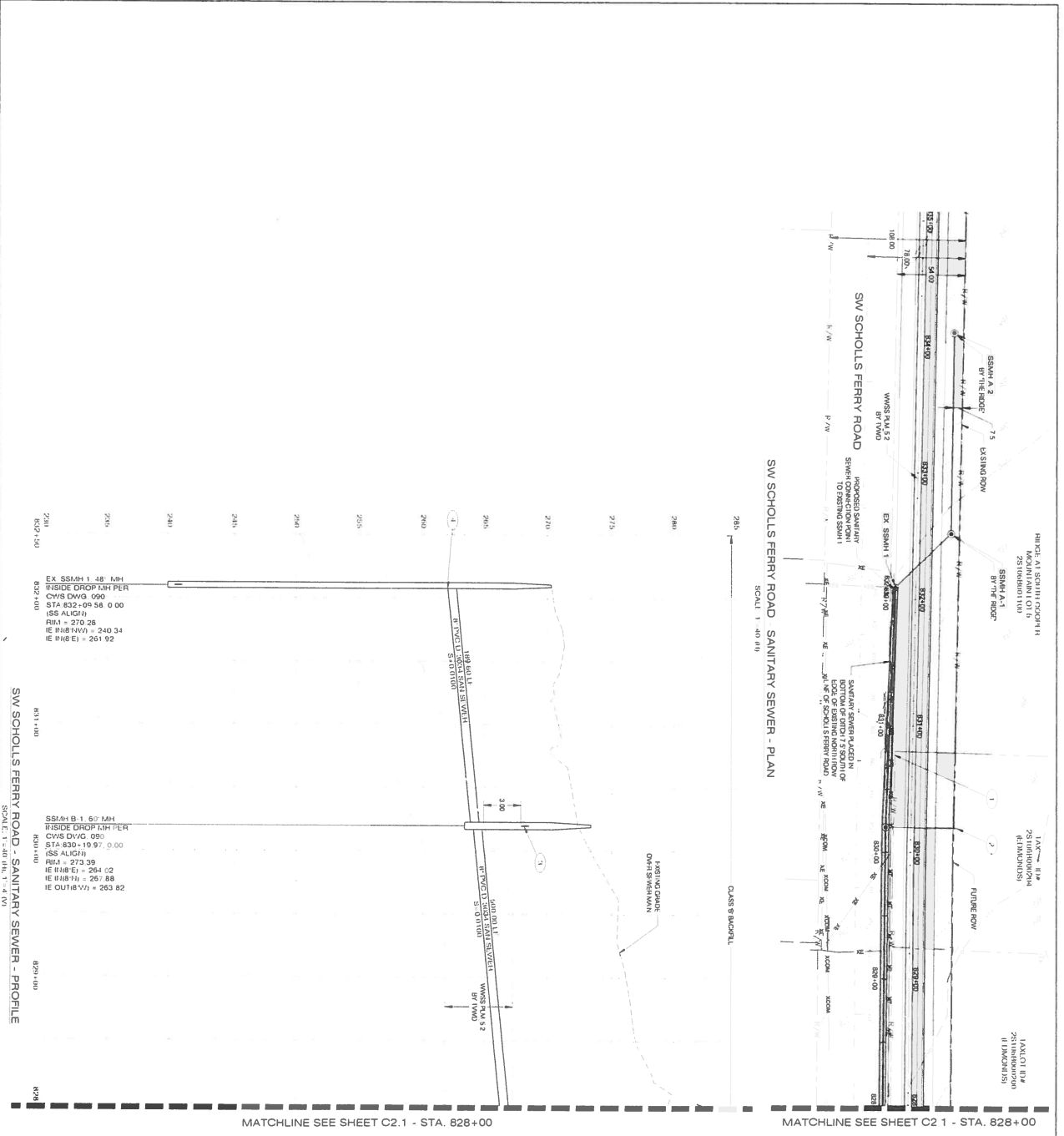

MATCHLINE SEE SHEET C2.1 - STA. 828+00

LEGEND

- EXISTING RIGHT-OF-WAY LINE
- EXISTING PROPERTY LINE
- EXISTING RIGHT-OF-WAY LINE
- FUTURE RIGHT-OF-WAY LINE
- FUTURE PROPERTY LINE
- FUTURE CURB AND GUTTER
- PROPOSED SANITARY LINE - 8" MANHOLE - OPTION 1
- PROPOSED SANITARY LINE - 8" MANHOLE - OPTION 2
- WWSW IN 5.2' BY 1.0' (WWSW)

SANITARY SEWER NOTES

- CONSTRUCTION SHALL INCLUDE PERMITTING, RIGHT-OF-WAY STAKED AND MAINTAINED, CONSTRUCTION ACTIVITIES TO WITHIN THE EXISTING RIGHT-OF-WAY AND MAINTAINING ACTIVITY OUTSIDE OF THE EXISTING RIGHT-OF-WAY. THE CONTRACTOR SHALL BE RESPONSIBLE FOR OBTAINING ALL NECESSARY PERMITS AND INSURING ACTIVITIES ON THE PRIVATE PROPERTY.
- MAINTAIN RIGHT-OF-WAY CONSTRUCTION WITHIN EXISTING RIGHT-OF-WAY. MAINTAIN EXISTING MANHOLE ELEVATIONS FROM CIVIL DRAWING 273-001. MAINTAIN EXISTING MANHOLE ELEVATIONS FROM CIVIL DRAWING 273-001. MAINTAIN EXISTING MANHOLE ELEVATIONS FROM CIVIL DRAWING 273-001.
- PROVIDE KNOCKOFF FOR FUTURE STUB.
- INSURE TEMP AND PERM. FOR CONSTRUCTION EXISTING MANHOLE ELEVATIONS FROM CIVIL DRAWING 273-001.

<p>Project No. 373-001 Type: SANITARY SEWER Sheet: C1.0</p>	<p>Date 10/30/2019 PER CDS REGULATIONS</p>	<p>Revision</p>	<p>By GAM</p>	<p>Designed by GAM Date 08/15/2015</p>	<p>Drawn by GAM Date 08/15/2015</p>	<p>Reviewed by GAM Date 08/15/2015</p>	<p>Project No. 373-001 REF.</p>	<p>Horiz. Scale</p>	<p>Vert. Scale</p>	<p>SANITARY SEWER PLAN AND PROFILE</p>	<p>HAACK PROPERTY BEAVERTON, WASHINGTON COUNTY, OREGON</p>		<p>PIONEER DESIGN GROUP ONE ENGINEERING PLAZA, SUITE 200, PORTLAND, OREGON 97208 HONOLULU, HAWAII 96813 TEL: 503.641.8216 FAX: 503.752.2170 WWW.PD-GRP.COM</p>

EXHIBIT C-3

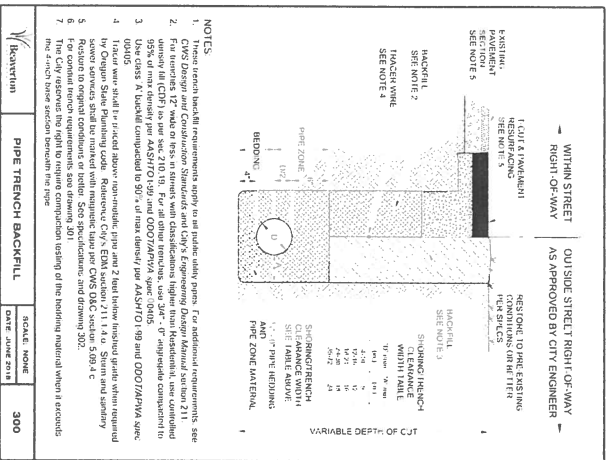
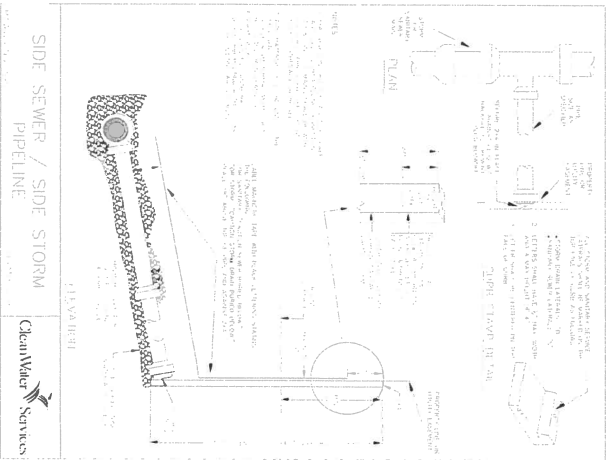
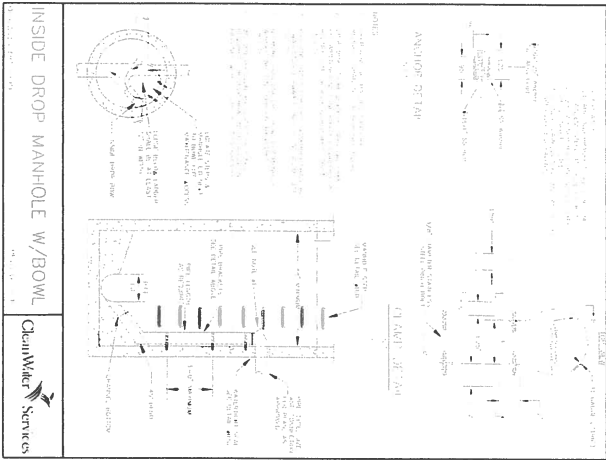
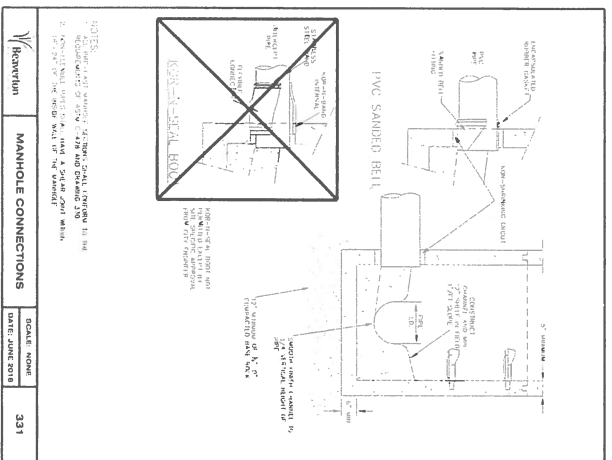
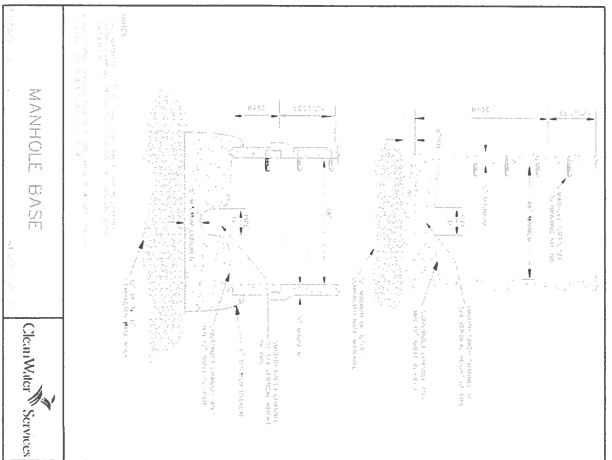
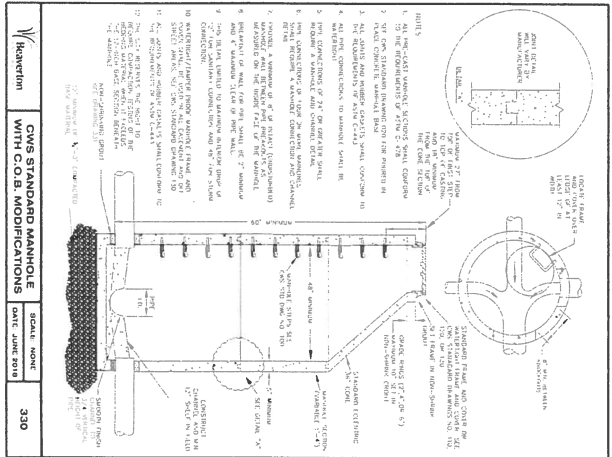

Designed by	GAM	Date	08/15/2015
Drawn by	GAM	Date	08/15/2015
Reviewed by	GAM	Date	08/15/2015
Project No.	373-001	REF	
Horiz. Scale:			
Vert. Scale:			

**CITY OF BEAVERTON & CWS
 STANDARD DETAILS**

HAACK PROPERTY
 BEAVERTON, WASHINGTON COUNTY, OREGON

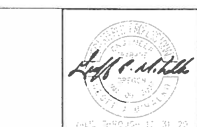

PIONEER DESIGN GROUP
 CIVIL ENGINEERING • LAND USE PLANNING • LAND DEVELOPMENT • LANDSCAPE ARCHITECTURE
 PORTLAND, OREGON | HONOLULU, HAWAII
 Ph: 503.443.1266 | Fax: 503.443.1267
 WWW.PD-GRP.COM

EXHIBIT C-6

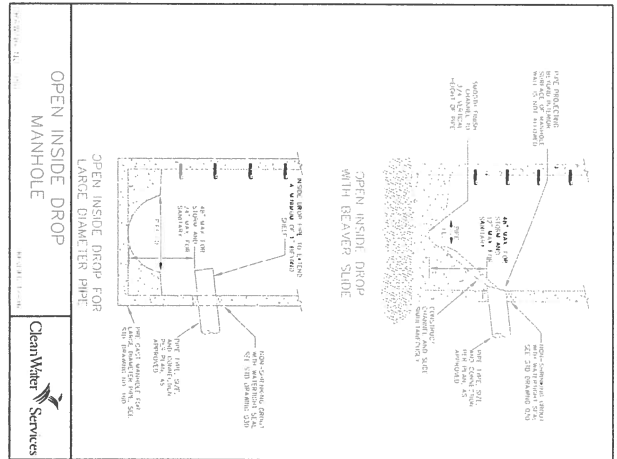

CleanWater Services

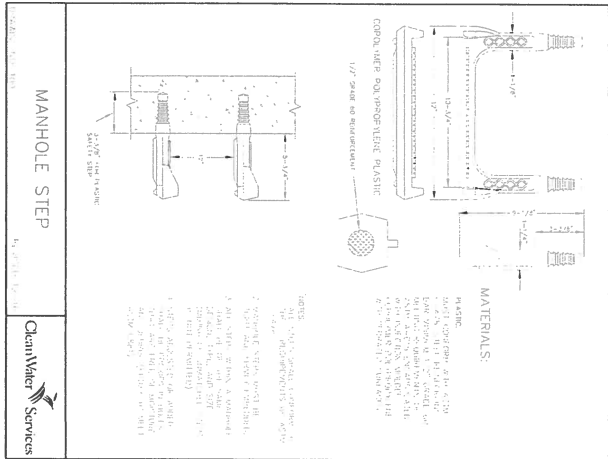

CleanWater Services

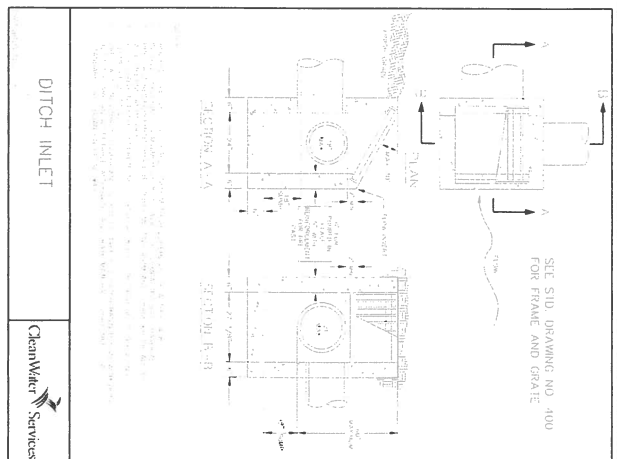

CleanWater Services

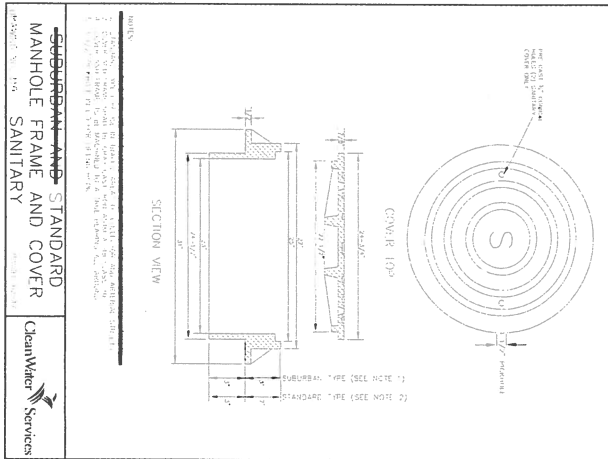

CleanWater Services

<p>C3.1</p>	<p>Project No. 173301 Type: CONCRETE Sheet: 1</p>	<p>No. 1 Date: 10/30/2019 Revision: PER CDS REDLINES</p>	<p>By: GAM</p>	<p>Designed by: GAM Date: 08/15/2015</p>	<p>Drawn by: GAM Date: 08/15/2015</p>	<p>Reviewed by: GAM Date: 08/15/2015</p>	<p>Project No.: 373-001 Ref.: REF.</p>	<p>Horiz. Scale: Vert. Scale:</p>	<p>CWS STANDARD DETAILS</p>	<p>HAACK PROPERTY BEAVERTON, WASHINGTON COUNTY, OREGON</p>		<p>PIONEER DESIGN GROUP Civil Engineering • Land Use Planning • Landscape Architecture Portland, Oregon • Honolulu, Hawaii Ph: 503-645-7206 Fax: 508-751-2370 www.pd-grp.com</p>
		<p>SEE STD. DRAWING NO. 400 FOR FRAME AND GRATE</p>										

EXHIBIT C-7

STAFF REPORT

To: Board of Commissioners

From: Dave Kraska, P.E., Willamette Water Supply System General Manager

Date: December 5, 2019

Subject: Amendments to Intergovernmental Agreements with Washington County for Design of PLM_4.1, PLM_4.2, and PLW_1.2

Requested Action:

Consider adopting three resolutions approving amendments to the Intergovernmental Agreements (IGAs) between Washington County and the Willamette Water Supply System (WWSS) Commission for the joint design of the following projects: PLM_4.1, PLM_4.2, and PLW_1.2.

Key Concepts:

- The Willamette Water Supply Program (WWSP) has strategically partnered with Washington County Land Use and Transportation (WCLUT) to deliver coordinated pipeline and roadway projects at various locations in the region and executed a memorandum of understanding for that purpose (Partnering MOU).
- Pursuant to the Partnering MOU, WWSP and WCLUT executed multiple intergovernmental agreements relating to PLM_4.1, PLM_4.2, and PLW_1.2 (Project IGAs).
- The Project IGAs have since been assigned to the WWSS Commission through the recently approved "Master IGA" between the WWSS Commission and WCLUT which replaced the Partnering MOU.
- There have been certain changes to the Project IGAs that require formalization through amendments to those agreements.
- The attached amendments to the Project IGAs incorporate needed updates to the agreements already in place for the design phase of each project.

Background:

Establishing effective partnerships has been an objective for the WWSP since its inception. With the support of the WWSS partner agencies, WWSP has established a strong partnership with WCLUT allowing for the design and construction of multiple pipeline projects in conjunction with WCLUT roadway projects. The desire to partner was memorialized in the Partnering MOU established in November of 2016, documenting the agencies' intentions to partner on road and waterline projects along SW Tualatin-Sherwood Road and SW Roy Rogers Road. Although not mentioned in the Partnering MOU, an additional partnered project exists along SW Cornelius Pass Road north of Tualatin-Valley Highway. These agreements will be under the umbrella of the recently approved Master IGA, which replaced the Partnering MOU.

The following Project IGAs require amendments to formalize changes such as: recognize the assignment from the Tualatin Valley Water District (TVWD) and the City of Hillsboro (Hillsboro) to the WWSS Commission, adding requirements for partnered projects to include Water Infrastructure Finance and

Innovation Act (WIFIA)-related contracting terms, clarifying responsibility for certain costs, and updating project schedules:

- Intergovernmental Agreement between Washington County and Tualatin Valley Water District and the City of Hillsboro for the Willamette Water Supply Program Joint Design of PLM_4.1 Highway 99 Crossing Pipeline and Tualatin-Sherwood Road – Langer Farms Parkway to Borchers Drive (2017, PLM_4.1) (Amendment One was executed in early 2019)
- Intergovernmental Agreement between Washington County and Tualatin Valley Water District and the City of Hillsboro for the Willamette Water Supply Program Joint Design of PLM_4.2 SW Tualatin-Sherwood Road - Teton to Langer Farms Parkway (2019, PLM_4.2)
- Intergovernmental Agreement between Washington County and Tualatin Valley Water District and the City of Hillsboro for the Willamette Water Supply Program for Joint Design of Cornelius Pass Road (Frances Street to Tualatin Valley Highway) and PLW_1.2 South Hillsboro Pipeline Projects (2017, PLW_1.2)

Budget Impact:

No budgetary impact. The funds for these efforts are included in the WWSP Baseline budget.

Staff Contact Information:

Dave Kraska, Willamette Water Supply System General Manager, 503-941-4561, david.kraska@tvwd.org
Clark Balfour, General Counsel, 503-848-3061, clark.balfour@tvwd.org

Attachments:

Project Area Map

Proposed Resolution for PLM_4.1

Exhibit 1: Intergovernmental Agreement Amendment Two between Washington County and the Willamette Water Supply System Commission for the Willamette Water Supply Program Joint Design of PLM_4.1 Highway 99 Crossing Pipeline and Tualatin-Sherwood Road – Langer Farms Parkway to Borchers Drive

Proposed Resolution for PLM_4.2

Exhibit 1: Intergovernmental Agreement Amendment One between Washington County and the Willamette Water Supply System Commission for the Willamette Water Supply Program Joint Design of PLM_4.2 SW Tualatin-Sherwood Road - Teton to Langer Farms Parkway

Proposed Resolution for PLW_1.2

Exhibit 1: Intergovernmental Agreement Amendment One between Washington County and the Willamette Water Supply System Commission for the Willamette Water Supply Program for Joint Design of Cornelius Pass Road (Frances Street to Tualatin Valley Highway) and PLW_1.2 South Hillsboro Pipeline Projects

Project Area Map:

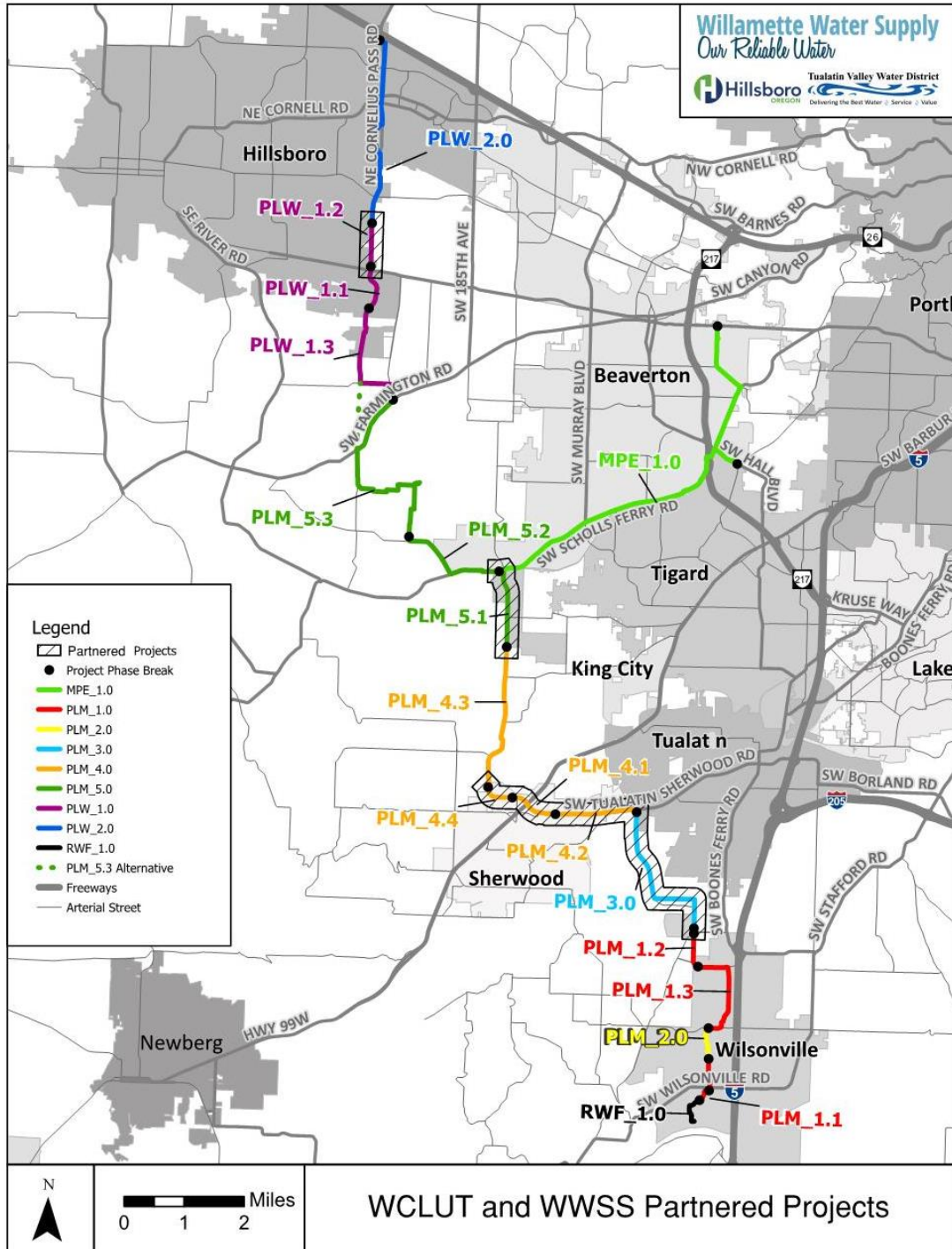

WCLUT and WWSS Partnered Projects

Willamette Water Supply System Commission

(this page intentionally left blank)

RESOLUTION NO. WWSS-14-19

A RESOLUTION AMENDING AN INTERGOVERNMENTAL AGREEMENT WITH WASHINGTON COUNTY FOR THE JOINT DESIGN OF PLM_4.1 HIGHWAY 99 CROSSING PIPELINE AND TUALATIN-SHERWOOD ROAD – LANGER FARMS PARKWAY TO BORCHERS DRIVE.

WHEREAS, in November of 2016, the Willamette Water Supply Program (“WWSP”), acting through the Tualatin Valley Water District and the City of Hillsboro, entered into a memorandum of understanding with Washington County Land Use and Transportation (“WCLUT”) for WWSP and WCLUT to deliver coordinated pipeline and roadway projects at various locations in the region (the “Partnering MOU”); and

WHEREAS, pursuant to the Partnering MOU, in June of 2017, WWSP and WCLUT entered into an intergovernmental agreement for the joint design of PLM_4.1 Highway 99 Crossing Pipeline and Tualatin-Sherwood – Langer Farms Parkway to Borchers Drive, later amended on February 19, 2019 (“IGA for Joint Design of PLM_4.1”); and

WHEREAS, the interests and obligations of the Tualatin Valley Water District and the City of Hillsboro have since been assigned to, and assumed by, the recently formed Willamette Water Supply System Commission (“Commission”); and

WHEREAS, the parties desire to amend, for the second time, the IGA for Joint Design of PLM_4.1 in order to recognize the assignment to the Commission; to add Water Infrastructure Finance and Innovation Act (WIFIA)-related contracting terms to the agreement; to clarify responsibilities for certain costs; and to update project schedules;

NOW, THEREFORE, BE IT RESOLVED BY THE WILLAMETTE WATER SUPPLY SYSTEM COMMISSION THAT:

Section 1: The Intergovernmental Agreement Amendment Two between Washington County and Willamette Water Supply System Commission for the Willamette Water Supply Program Joint Design of PLM_4.1 Highway 99 Crossing Pipeline and Tualatin-Sherwood – Langer Farms Parkway to Borchers Drive, attached hereto as Exhibit 1 and incorporated herein by this reference, is approved.

Section 2: The General Manager is hereby directed to work with the Commission’s legal counsel to finalize the agreement, including by making any non-substantive changes to the form and format, and is authorized to execute the Agreement on behalf of the Commission.

Approved and adopted at a regular meeting held on the 5th day of December, 2019.

James Duggan, Chair

Denny Doyle, Vice Chair

Willamette Water Supply System Commission

(this page intentionally left blank)

Exhibit 1 to Resolution No. WWSS-14-19**AMENDMENT TWO TO****INTERGOVERNMENTAL AGREEMENT****BETWEEN****WASHINGTON COUNTY AND
THE WILLAMETTE WATER SUPPLY SYSTEM COMMISSION
FOR THE WILLAMETTE WATER SUPPLY PROGRAM****JOINT DESIGN****PLM_4.1 HIGHWAY 99 CROSSING PIPELINE AND TUALATIN SHERWOOD ROAD –
LANGER FARMS PARKWAY TO BORCHERS DRIVE**

This Amendment Two ("Amendment") is made and entered into between Washington County, a political subdivision of the State of Oregon, acting by and through its Board of County Commissioners, hereinafter referred to as "COUNTY", and the Willamette Water Supply System Commission, an Oregon intergovernmental entity, hereinafter referred to as the "WWSS Commission". COUNTY and the WWSS Commission are collectively referred to herein as "Parties."

RECITALS

- A. WHEREAS, the County previously entered into the Intergovernmental Agreement for Joint Design of PLM_4.1 Highway 99 Crossing Pipeline and Tualatin Sherwood Road – Langer Farms Parkway to Borchers Drive, executed on March 24, 2017 ("Agreement") with Tualatin Valley Water District ("TVWD") and the City of Hillsboro ("City") (jointly, "WWSS Commission's Predecessors"); and
- B. WHEREAS, the Agreement was previously amended by Amendment Two, executed on February 19, 2019; and
- C. WHEREAS, the Parties have executed that certain Master Project Coordination Intergovernmental Agreement ("Master IGA") acknowledging assignment of the Agreement from the WWSS Commission's Predecessors to the WWSS Commission; and
- D. WHEREAS the WWSS Commission still plans, designs, and constructs the Willamette Water Supply System through the Willamette Water Supply Program ("WWSP"), and
- E. WHEREAS, the Parties desire to amend the Agreement to reflect various administrative changes in the development of the Project, as that term is defined in the Agreement.

AGREEMENT

NOW, THEREFORE, in consideration of the terms, conditions, and covenants set forth below, the Parties amend the Agreement as follows:

1. All references in the Agreement to TVWD and the City, and all references in the

Agreement to the WWSP, shall be deemed references to the WWSS Commission.

2. Add Recital I:

WHEREAS, the WWSS Commission anticipates using Water Infrastructure Finance and Innovation Act ("WIFIA") funding for Waterline Work, which requires compliance with certain conditions, including, but not limited to, Davis-Bacon and Related Acts, American Iron and Steel Act, Disadvantaged Business Enterprises Program, regulations governing debarment and suspension, Equal Employment Opportunity Executive Order, civil rights laws, Drug-Free Workplace Act, and restrictions on lobbying; and

3. Add the following language immediately after the existing language in Article 2.1:

Excluding shared costs, Road Work will be funded solely by COUNTY and not with WIFIA funds. However, because Road Work will be constructed with the Waterline Work of PLM_4.1, some WIFIA requirements may be coincidentally applied to the Road Work. Nonetheless, the WWSS Commission shall not pay for any portion of Road Work.

4. Add the following language immediately after the existing language in Article 2.2:

The WWSS Commission intends to use WIFIA funding for the Waterline Work.

5. Add the following language immediately after the existing language in Article 3.8:

Front-end documents shall include requirements for contractor and subcontractor compliance with all laws as required by WIFIA, including, but not limited to, Davis-Bacon and related acts, American Iron and Steel Act, Disadvantaged Business Enterprises Program, regulations governing debarment and suspension, Equal Employment Opportunity Executive Order, civil rights laws, Drug-Free Workplace Act, and restrictions on lobbying.

6. Add Article 3.9:

COUNTY shall include a bidding period of not less than 30 days in the project schedule in order to be compliant with the WIFIA requirements for the Waterline Work.

7. Revise Article 7.2 to add the following paragraph at the end of the current language in that section:

Notwithstanding the foregoing, the Parties understand that the Project must be completed according to the key milestones identified in Exhibit 2-2 (revised) and agree to work collaboratively to meet the established milestones. If a Party is unable to proceed with the Project in accordance with the aforementioned milestones, the other Party retains the right to independently continue that Party's part of the Project according to the milestones in Exhibit 2-2 (revised). In that event, the Party desiring to continue its part of the project shall provide notice to the other Party, and the other Party shall complete its portion of the Project in a manner that does not impede or interfere with the work of the Party meeting the milestones in Exhibit 2-2 (revised).

8. Add Article 7.12, Assignment/Additional Parties:

TVWD, Hillsboro, and Beaverton may create further Intergovernmental Agreement(s)

between them as well as with other municipal water suppliers that may own or use the Waterline Work and the System. Upon reasonable written notice, COUNTY agrees to assignment by WWSS Commission of the rights, obligations, and covenants of this Agreement to include those municipal water suppliers individually, along with TVWD, Hillsboro, and Beaverton, or to assign rights, obligations, and covenants of this Agreement to a successor intergovernmental entity formed by TVWD, Hillsboro, and Beaverton under ORS Chapter 190.

9. Exhibit 2 shall be replaced with a new Exhibit 2-2 (revised), attached hereto and incorporated by reference.
10. Exhibit 3 shall be replaced with a new Exhibit 3-2 (revised), attached hereto and incorporated by reference.
11. To the extent that the provisions of this Amendment Two are inconsistent with the provisions of the Agreement, Amendment One, or the Master IGA, the Parties intend for this Amendment Two to be controlling. Except as expressly provided in this Amendment Two, the Parties do not intend for this Amendment Two to affect, modify, repeal, replace, or amend any other term, condition, or provision of the Agreement or Amendment One, which shall remain in full force and effect subject to this Amendment Two.

IN WITNESS WHEREOF, the Parties hereto have set their hands as of the day and year hereinafter written.

WASHINGTON COUNTY, OREGON

**WILLAMETTE WATER SUPPLY
SYSTEM COMMISSION**

By _____

By _____

Print Name: Kathryn Harrington,
As Its Chair Washington County Board
of Commissioners

Print Name: David Kraska,
As Its General Manager

Date _____

Date _____

Approved as to Form

PLM_4.1 HIGHWAY 99 CROSSING PIPELINE AND TUALATIN SHERWOOD ROAD – LANGER FARMS PARKWAY TO BORCHERS DRIVE

**Exhibit 2-2
Cost Breakdown Table**

Description	Original IGA	Amendment 1	Amendment 2	Total
1. Geotechnical Investigations	\$ -	\$ -	\$ -	\$ -
2. Secondary Geotechnical Investigations	\$ -	\$ -	\$ -	\$ -
3. Topographic & Utility Survey	\$ 12,000.00	\$ -	\$ 4,564.15	\$ 16,564.15
4. Right of Way	\$ -	\$ -	\$ -	\$ -
5. Permitting	\$ -	\$ -	\$ 19,053.64	\$ 19,053.64
6. Wetland Delineation	\$ -	\$ -		\$ -
7. Public Outreach Services	\$ -	\$ -	\$ 19,524.69	\$ 19,524.69
8. Design Package Integration	\$ 24,000.00	\$ -	\$ -	\$ 24,000.00
9. Bidding	\$ 10,000.00	\$ -	\$ 6,158.06	\$ 16,158.06
10. Consultant Administration/PM Costs	\$ 1,830.00	\$ 6,600.00	\$ 28,672.36	\$ 37,102.36
11. Traffic Control Plans	\$ -	\$ 60,000.00	\$ -	\$ 60,000.00
12. ODOT Plan Review Fee	\$ -	\$ 10,000.00	\$ -	\$ 10,000.00
13. Final Design	\$ -	\$ -	\$ 238,955.02	\$ 238,955.02
14. Hazardous Materials Investigations	\$ -	\$ -		\$ -
15. Additional Services as Requested	\$ -	\$ -	\$ 12,500.00	\$ 12,500.00
16. 15% WCLUT Admin/PM (Org IGA + Amd 1 + Amd 2)			\$ 68,078.69	\$ 68,078.69
Total	\$ 47,830.00	\$ 76,600.00	\$ 397,506.61	\$ 521,936.61

Willamette Water Supply System Commission

(this page intentionally left blank)

**PLM_4.1 HIGHWAY 99 CROSSING PIPELINE AND TUALATIN SHERWOOD ROAD –
LANGER FARMS PARKWAY TO BORCHERS DRIVE**

Exhibit 3-2 (Revised)

Scheduled Design Milestones

Milestone	Project Planning Dates*	Project Milestone Dates
Design Notice to Proceed	Not applicable. Project has begun.	Not applicable.
30% WWSP / 50% WCLUT Design Submittal	Not applicable. Design completed.	Not applicable.
60% WWSP Design Submittal	Not applicable. Design completed.	Not applicable.
95%% WWSP Design Submittal	December 1,2019	March 6, 2020
90% WCLUT Design Submittal	December 1, 2019	April 3, 2020
Submit Permit Applications	January 31, 2020	April 3, 2020
Begin Property Acquisition	December 2, 2019	April 30, 2020
Bid Advertisement	November 1, 2020	January 4, 2021
Construction Notice to Proceed	February 1, 2021	April 5, 2021
Waterline Work Begin Construction	February 1, 2022	April 4, 2022
Waterline Work Substantially Complete	February 1, 2023	April 7, 2023
Construction Substantial Completion	October 2024	October 2024

- Dates subject to change with approval by the Voting Members of the Stage Gate Review Committee.

Willamette Water Supply System Commission

(this page intentionally left blank)

RESOLUTION NO. WWSS-15-19

A RESOLUTION AMENDING AN INTERGOVERNMENTAL AGREEMENT WITH WASHINGTON COUNTY FOR THE JOINT DESIGN OF PLM_4.2 SW TUALATIN-SHERWOOD ROAD – TETON TO LANGER FARMS PARKWAY.

WHEREAS, in November of 2016, the Willamette Water Supply Program (“WWSP”), acting through the Tualatin Valley Water District and the City of Hillsboro, entered into a memorandum of understanding with Washington County Land Use and Transportation (“WCLUT”) for WWSP and WCLUT to deliver coordinated pipeline and roadway projects at various locations in the region (the “Partnering MOU”); and

WHEREAS, pursuant to the Partnering MOU, in February of 2019, WWSP and WCLUT entered into an intergovernmental agreement for the joint design of PLM_4.2 SW Tualatin-Sherwood Road – Teton to Langer Farms Parkway (“IGA for Joint Design of PLM_4.2”); and

WHEREAS, the interests and obligations of the Tualatin Valley Water District and the City of Hillsboro have since been assigned to, and assumed by, the recently formed Willamette Water Supply System Commission (“Commission”); and

WHEREAS, the parties desire to amend the IGA for Joint Design of PLM_4.2 in order to recognize the assignment to the Commission; to add Water Infrastructure Finance and Innovation Act (WIFIA)-related contracting terms to the agreement; to clarify responsibilities for certain costs; and to update project schedules;

NOW, THEREFORE, BE IT RESOLVED BY THE WILLAMETTE WATER SUPPLY SYSTEM COMMISSION THAT:

Section 1: The Intergovernmental Agreement Amendment One between Washington County and the Willamette Water Supply System Commission for the Willamette Water Supply Program Joint Design of PLM_4.2 SW Tualatin-Sherwood Road – Teton to Langer Farms Parkway, attached hereto as Exhibit 1 and incorporated herein by this reference, is approved.

Section 2: The General Manager is hereby directed to work with the Commission’s legal counsel to finalize the agreement, including by making any non-substantive changes to the form and format, and is authorized to execute the Agreement on behalf of the Commission.

Approved and adopted at a regular meeting held on the 5th day of December, 2019.

James Duggan, Chair

Denny Doyle, Vice Chair

Willamette Water Supply System Commission

(this page intentionally left blank)

INTERGOVERNMENTAL AGREEMENT AMENDMENT ONE

BETWEEN

**WASHINGTON COUNTY AND
THE WILLAMETTE WATER SUPPLY SYSTEM COMMISSION
FOR THE WILLAMETTE WATER SUPPLY PROGRAM**

JOINT DESIGN

PLM_4.2 TUALATIN SHERWOOD ROAD – TETON TO LANGER FARMS PARKWAY

This Amendment One ("Amendment") is made and entered into between Washington County, a political subdivision of the State of Oregon, acting by and through its Board of County Commissioners, hereinafter referred to as "COUNTY", and the Willamette Water Supply System Commission, an Oregon intergovernmental entity, hereinafter referred to as the "WWSS Commission". COUNTY and the WWSS Commission are collectively referred to herein as "Parties."

RECITALS

- A. WHEREAS, the County previously entered into the Intergovernmental Agreement for Joint Design of PLM_4.2 Tualatin Sherwood Road – Teton to Langer Farms Parkway, executed on February 19, 2019 ("Agreement") with Tualatin Valley Water District ("TVWD") and the City of Hillsboro ("City") (jointly, "WWSS Commission's Predecessors"); and
- B. WHEREAS, the Parties have executed that certain Master Project Coordination Intergovernmental Agreement ("Master IGA") acknowledging assignment of the Agreement from the WWSS Commission's Predecessors to the WWSS Commission; and
- C. WHEREAS the WWSS Commission still plans, designs, and constructs the Willamette Water Supply System through the Willamette Water Supply Program ("WWSP"), and
- D. WHEREAS, the Parties desire to amend the Agreement to reflect various administrative changes in the development of the Project, as that term is defined in the Agreement.

AGREEMENT

NOW, THEREFORE, in consideration of the terms, conditions, and covenants set forth below, the Parties amend the Agreement as follows:

- 1. All references in the Agreement to TVWD and the City, and all references in the Agreement to the WWSP, shall be deemed references to the WWSS Commission.
- 2. Add to the Recitals section a "Recital J" that reads as follows:

WHEREAS, the WWSS Commission anticipates using Water Infrastructure Finance and Innovation Act ("WIFIA") funding for Waterline Work, which requires compliance with certain conditions, including, but not limited to, Davis-Bacon and related acts, American Iron and Steel Act, Disadvantaged Business Enterprises Program, regulations governing debarment and suspension, Equal Employment Opportunity Executive Order, civil rights

laws, Drug-Free Workplace Act, and restrictions on lobbying; and

3. Exhibit 3 shall be replaced with and superseded by a new Exhibit 3-1 (revised), attached hereto and incorporated by reference.

4. Add the following language immediately after the existing language in Article 2.1:

Excluding shared costs, Road Work will be funded solely by COUNTY and not with WIFIA funds. However, because Road Work will be constructed with the Waterline Work of PLM 4.2, some WIFIA requirements may be coincidentally applied to the Road Work. Nonetheless, the WWSS Commission shall not pay for any portion of Road Work.

5. Add the following language immediately after the existing language in Article 2.2:

The WWSS Commission intends to use WIFIA funding for the Waterline Work.

6. Add the following language immediately after the existing language in Article 3.8:

Front-end documents shall include requirements for contractor and subcontractor compliance with all laws as required by WIFIA, including, but not limited to, Davis-Bacon and related acts, American Iron and Steel Act, Disadvantaged Business Enterprises Program, regulations governing debarment and suspension, Equal Employment Opportunity Executive Order, civil rights laws, Drug-Free Workplace Act, and restrictions on lobbying.

7. Add Article 3.10:

COUNTY shall include a bidding period of not less than thirty (30) days in the project schedule in order to be compliant with the WIFIA requirements for the Waterline Work.

8. Revise Article 7.2 to add the following paragraph at the end of the current language in that section:

Notwithstanding the foregoing, the Parties understand that the Project must be completed according to the key milestones identified in Exhibit 3-1 (revised) and agree to work collaboratively to meet the established milestones. If a Party is unable to proceed with the Project in accordance with the aforementioned milestones, the other Party retains the right to independently continue that Party's part of the Project according to the milestones in Exhibit 3-1 (revised). In that event, the Party desiring to continue its part of the project shall provide notice to the other Party, and the other Party shall complete its portion of the Project in a manner that does not impede or interfere with the work of the Party meeting the milestones in Exhibit 3-1 (revised).

9. To the extent that the provisions of this Amendment One are inconsistent with the provisions of the Agreement or the Master IGA, the Parties intend for this Amendment One to be controlling. Except as expressly provided in this Amendment One, the Parties do not intend for this Amendment One to affect, modify, repeal, replace, or amend any other term, condition, or provision of the Agreement, which shall remain in full force and effect subject to this Amendment One.

IN WITNESS WHEREOF, the Parties hereto have set their hands as of the day and year hereinafter written.

WASHINGTON COUNTY, OREGON

**WILLAMETTE WATER SUPPLY
SYSTEM COMMISSION**

By _____

By _____

Print Name: Kathryn Harrington,
As Its Chair Washington County Board
of Commissioners

Print Name: David Kraska,
As Its General Manager

Date _____

Date _____

Approved as to Form

Willamette Water Supply System Commission

(this page intentionally left blank)

PLM_4.2 SW TUALATIN-SHERWOOD RD – TETON TO LANGER FARMS PKWY

Exhibit 3-1

Scheduled Design Milestones

Milestone	Date
Design Notice to Proceed	
30% WCLUT Design Submittal (includes Basemap)	October, 2019
30% WWSP Design Submittal	December 16, 2019
60% WWSP Design Submittal	February 28, 2020
60% WCLUT Design Submittal	February 28, 2020
90% WWSP Design Submittal	August 31, 2020
90% WCLUT Design Submittal	August 31, 2020
100% WWSP Design Submittal	October 31, 2020
100% WCLUT Design Submittal	October 31, 2020
Submit Permit Applications	July 1, 2020
Begin Property Acquisition	July 1 2020
Bid Advertisement	March 8, 2021
Construction Notice to Proceed	June 2, 2021
Waterline Work Begin Construction	June 3, 2022
Waterline Work Substantially Complete	June 30, 2023
Construction Substantial Completion	November 30, 2024

Willamette Water Supply System Commission

(this page intentionally left blank)

RESOLUTION NO. WWSS-16-19

A RESOLUTION AMENDING AN INTERGOVERNMENTAL AGREEMENT WITH WASHINGTON COUNTY FOR THE JOINT DESIGN OF CORNELIUS PASS ROAD AND PLW_1.2 SOUTH HILLSBORO PIPELINE PROJECTS.

WHEREAS, in November of 2016, the Willamette Water Supply Program (“WWSP”), acting through the Tualatin Valley Water District and the City of Hillsboro, entered into a memorandum of understanding with Washington County Land Use and Transportation (“WCLUT”) for WWSP and WCLUT to deliver coordinated pipeline and roadway projects at various locations in the region (the “Partnering MOU”); and

WHEREAS, pursuant to the Partnering MOU, in July of 2017, WWSP and WCLUT entered into an intergovernmental agreement for the joint design of Cornelius Pass Road (Frances Street to Tualatin Valley Highway) and PLW_1.2 South Hillsboro Pipeline Projects (“IGA for Joint Design of Cornelius Pass Road and PLW_1.2”); and

WHEREAS, the interests and obligations of the Tualatin Valley Water District and the City of Hillsboro have since been assigned to, and assumed by, the recently formed Willamette Water Supply System Commission (“Commission”); and

WHEREAS, the parties desire to amend the IGA for Joint Design of Cornelius Pass Road and PLW_1.2 in order to recognize the assignment to the Commission; to add Water Infrastructure Finance and Innovation Act (WIFIA)-related contracting terms to the agreement; to clarify responsibilities for certain costs; and to update project schedules;

NOW, THEREFORE, BE IT RESOLVED BY THE WILLAMETTE WATER SUPPLY SYSTEM COMMISSION THAT:

Section 1: The Intergovernmental Agreement Amendment One between Washington County and the Willamette Water Supply System Commission for the Willamette Water Supply Program for Joint Design of Cornelius Pass Road (Frances Street to Tualatin Valley Highway) and PLW_1.2 South Hillsboro Pipeline Projects, attached hereto as Exhibit 1 and incorporated herein by this reference, is approved.

Section 2: The General Manager is hereby directed to work with the Commission’s legal counsel to finalize the agreement, including by making any non-substantive changes to the form and format, and is authorized to execute the Agreement on behalf of the Commission.

Approved and adopted at a regular meeting held on the 5th day of December, 2019.

James Duggan, Chair

Denny Doyle, Vice Chair

Willamette Water Supply System Commission

(this page intentionally left blank)

INTERGOVERNMENTAL AGREEMENT AMENDMENT ONE

BETWEEN

**WASHINGTON COUNTY AND
WILLAMETTE WATER SUPPLY SYSTEM COMMISSION
FOR THE WILLAMETTE WATER SUPPLY PROGRAM**

JOINT DESIGN

**CORNELIUS PASS ROAD (FRANCES STREET TO TUALATIN VALLEY HIGHWAY) AND
PLW_1.2 SOUTH HILLSBORO PIPELINE PROJECTS**

This Amendment One ("Amendment") is made and entered into between Washington County, a political subdivision of the State of Oregon, acting by and through its Board of County Commissioners, hereinafter referred to as "COUNTY", and the Willamette Water Supply System Commission, an Oregon intergovernmental entity, hereinafter referred to as the "WWSS Commission". COUNTY and the WWSS Commission are collectively referred to herein as "Parties."

RECITALS

- A. WHEREAS, the County previously entered into the Intergovernmental Agreement for Joint Design of Cornelius Pass Road (Frances Street to Tualatin Valley Highway) and PLW_1.2 South Hillsboro Pipeline Projects, executed on July 18, 2017 ("Agreement") with Tualatin Valley Water District ("TVWD") and the City of Hillsboro ("City") (jointly, "WWSS Commission's Predecessors"); and
- B. WHEREAS, the Parties have executed that certain Master Project Coordination Intergovernmental Agreement ("Master IGA") acknowledging assignment of the Agreement from the WWSS Commission's Predecessors to the WWSS Commission; and
- C. WHEREAS the WWSS Commission still plans, designs, and constructs the Willamette Water Supply System through the Willamette Water Supply Program ("WWSP"), and
- D. WHEREAS, the Parties desire to amend the Agreement to reflect various administrative changes in the development of the Project, as that term is defined in the Agreement.

AGREEMENT

NOW, THEREFORE, in consideration of the terms, conditions, and covenants set forth below, the Parties amend the Agreement as follows:

- 1. All references in the Agreement to TVWD and the City, and all references in the Agreement to the WWSP, shall be deemed references to the WWSS Commission.
- 2. Add to the Recitals section a "Recital I" that reads as follows:

WHEREAS, the WWSS Commission anticipates using Water Infrastructure Finance and Innovation Act ("WIFIA") funding for Waterline Work, which requires compliance with certain conditions, including, but not limited to, Davis-Bacon and related acts, American

Iron and Steel Act, Disadvantaged Business Enterprises Program, regulations governing debarment and suspension, Equal Employment Opportunity Executive Order, civil rights laws, Drug-Free Workplace Act, and restrictions on lobbying; and

3. Add the following language immediately after the existing language in Article 2.1:

Excluding shared costs, Road Work will be funded solely by COUNTY and not with WIFIA funds. WIFIA Program Requirements will not be required for Road Work. However, because Road Work will be constructed with the Waterline Work of PLW_1.2, some WIFIA requirements may be coincidentally applied to the Road Work. Nonetheless, the WWSS Commission shall not pay for any portion of Road Work.

4. Add the following language immediately after the existing language in Article 2.2:

The WWSS Commission intends to use WIFIA funding for the Waterline Work. In the event compliance, implementation, or enforcement of WIFIA Program Requirements result in any increased costs for the Road Work, including Shared Costs, such increases shall be the sole and total obligation of the WWSS Commission, independent and separate from the WWSS Commission's other financial obligations provided in this Agreement.

5. Add the following language immediately after the existing language in Article 3.8:

Front-end documents shall include requirements for contractor and subcontractor compliance with all laws as required by WIFIA, including, but not limited to, Davis-Bacon and related acts, American Iron and Steel Act, Disadvantaged Business Enterprises Program, regulations governing debarment and suspension, Equal Employment Opportunity Executive Order, civil rights laws, Drug-Free Workplace Act, and restrictions on lobbying.

6. Add Article 3.9:

COUNTY shall include a bidding period of not less than thirty (30) days in the project schedule in order to be compliant with the WIFIA requirements for the Waterline Work.

7. Revise Article 7.2 to add the following paragraph at the end of the current language in that section:

Notwithstanding the foregoing, the Parties understand that the Project must be completed according to the key milestones identified in Exhibit 3 and agree to work collaboratively to meet the target milestones. If a Party is unable to proceed with the Project in accordance with the aforementioned milestones, the other Party retains the right to independently continue that Party's part of the Project according to the milestones in Exhibit 3. In that event, the Party desiring to continue its part of the project shall provide notice to the other Party, and the other Party shall complete its portion of the Project in a manner that does not impede or interfere with the work of the Party meeting the milestones in Exhibit 3.

8. Exhibit 3 shall be replaced with and superseded by a new Exhibit 3-1 (revised), attached hereto and incorporated by reference.

9. To the extent that the provisions of this Amendment One are inconsistent with the provisions of the Agreement or the Provisions of the Master IGA, the Parties intend for this Amendment One to be controlling. Except as expressly provided in this Amendment

One, the Parties do not intend for this Amendment One to affect, modify, repeal, replace, or amend any other term, condition, or provision of the Agreement, which shall remain in full force and effect subject to this Amendment One.

IN WITNESS WHEREOF, the Parties hereto have set their hands as of the day and year hereinafter written.

WASHINGTON COUNTY, OREGON

**WILLAMETTE WATER SUPPLY
SYSTEM COMMISSION**

By _____

By _____

Print Name: Kathryn Harrington,
As Its Chair Washington County Board
of Commissioners

Print Name: David Kraska,
As Its General Manager

Date _____

Date _____

Approved as to Form

**CORNELIUS PASS RD WIDENING AND
PLW_1.2 TV HWY TO FRANCE RD PIPELINE PROJECT**

Exhibit 3-1

Scheduled Design Milestones

Milestone	Date
Design Notice to Proceed	Complete
30% WWSP Design Submittal	Complete
30% WCLUT Design Submittal	Complete
60% WCLUT Design Submittal	Complete
90% WWSP / WCLUT Design Submittal	Complete
60% WWSP Design Re-Submittal	November 2019
90% WWSP Design Re-Submittal	February 2020
100% WCLUT Design Submittal	March 2020
100% WWSP Design Submittal	April 2020
Bid Advertisement	November 2021
Construction Notice to Proceed	January 2022
Substantial Completion	October 2023

STAFF REPORT

To: WWSS Board of Commissioners
From: David Kraska, P.E., Willamette Water Supply System General Manager
Date: December 5, 2019
Subject: Request to Local Contract Review Board for Appointment of the WWSS Commission General Manager as Public Contracting Officer and Approval of Other Clarifying Procurement Provisions

Requested Board Action:

Acting as the Local Contract Review Board (LCRB), consider adopting a resolution approving appointment of the Willamette Water Supply System (“WWSS”) Commission’s General Manager as Public Contracting Officer (“PCO”) and other clarifications to the Local Contract Review Board Rules (“Procurement Rules”).

Key Concepts:

- The proposed resolution provides clarity regarding the application of the Managing Agency’s Procurement Rules for purposes of WWSS Commission business.
- The proposed resolution clarifies that references to the “Board” mean the governing body of the Commission, acting as the LCRB for the Commission, and that references to “District Staff” mean employees or agents of the Commission designated by the WWSS General Manager.
- The proposed resolution also clarifies that references to the “Public Contracting Officer” or “PCO” mean the WWSS General Manager and that the General Manager has the authority to interpret the Procurement Rules to ensure the efficient, reasonable, and lawful administration and application of the Procurement Rules.

Background:

The Commission has adopted Procurement Rules and serves as the Commission’s LCRB. Through Resolution No. WWSS-02-19 the Commission adopted the Procurement Rules of the Managing Agency to govern all contracts and purchases until the Commission takes further action. Those rules assign certain roles and responsibilities to the governing body and staff. The proposed resolution provides clarity regarding those assignments for purposes of conducting WWSS Commission business.

Budget Impact:

There are no budgetary impacts anticipated from this item.

Staff Contact Information:

David Kraska, P.E., WWSP Program Director; 503-941-4561; david.kraska@tvwd.org
Clark Balfour, General Counsel; 503-848-3061; clark.balfour@tvwd.org

Attachments:

1. Proposed Local Contract Review Board resolution

Willamette Water Supply System Commission

(this page intentionally left blank)

RESOLUTION NO. WWSS-17-19

A RESOLUTION OF THE WILLAMETTE WATER SUPPLY SYSTEM COMMISSION, IN ITS CAPACITY AS THE LOCAL CONTRACT REVIEW BOARD, APPOINTING THE GENERAL MANAGER AS THE PUBLIC CONTRACTING OFFICER AND CLARIFYING OTHER PROCUREMENT PROVISIONS.

WHEREAS, Section 5.4.8 of the Willamette Water Supply System Intergovernmental Agreement (“WWSS IGA”) vests the Willamette Water Supply System Commission (“Commission”) with the authority to adopt contracting rules and to serve as the Commission’s Local Contract Review Board pursuant to ORS Chapter 279A; and

WHEREAS, Section 6.1 of the WWSS IGA designates Tualatin Valley Water District as the Managing Agency for the Commission; and

WHEREAS, the Commission, in Resolution No. WWSS-02-19, adopted the Local Contract Review Board Rules (“Procurement Rules”) of the Managing Agency to govern all contracts and purchases until the Commission takes further action; and

WHEREAS, the Commission desires to clarify the roles of the Commission, its employees, and its agents with respect to the implementation of the Procurement Rules;

NOW, THEREFORE, BE IT RESOLVED BY THE BOARD OF COMMISSIONERS OF THE WILLAMETTE WATER SUPPLY SYSTEM COMMISSION, ACTING AS THE LOCAL CONTRACT REVIEW BOARD, THAT:

Section 1: References to the “Board” in the Procurement Rules shall mean the governing body of the Commission acting as the Local Contract Review Board for the Commission.

Section 2: References to “District Staff” in the Procurement Rules shall mean the employees or agents of the Commission designated by the General Manager to act as staff for that purpose.

Section 3: References to the “Public Contracting Officer” or “PCO” in the Procurement Rules shall mean the Commission’s General Manager or the General Manager’s designee.

Section 4: The General Manager shall have authority to interpret the Procurement Rules to ensure the efficient, reasonable, and lawful administration and application of the Procurement Rules for contracts entered into by the Commission.

Approved and adopted at a regular meeting held on the 5th day of December 2019.

James Duggan, Chair

Denny Doyle, Vice Chair

Willamette Water Supply System Commission

(this page intentionally left blank)

STAFF REPORT

To: WWSS Board of Commissioners
From: David Kraska, P.E., Willamette Water Supply System General Manager
Date: December 5, 2019
Subject: Request to Local Contract Review Board for Exemption from Competitive Bidding for Upcoming Water Transmission Pipeline Projects

Requested Board Action:

Acting as the Local Contract Review Board (LCRB), consider approving a motion to read by title only a draft resolution declaring an exemption from competitive bidding for a class of pipeline projects and approving the use of best value selection method for construction contractors, receive oral testimony or written comments and direct that the resolution be brought back for a second reading and adoption at the January 9, 2020 Board meeting.

Key Concepts:

- The draft resolution declaring an exemption from competitive bidding under ORS 279C.300 allows the use of best value selection for construction contractors for Willamette Water Supply System projects: PLM_1.3, PLM_4.3, and PLW_1.3.
- These projects are recommended for best value selection based on an evaluation of the remaining construction projects for which the Willamette Water Supply Program (WWSP) will lead the procurement.
- Best value selection would enable consideration of a combination of cost and qualifications specific to each project, including technical approach and specialized expertise relevant to specific project requirements.
- The existing pool of prequalified pipeline contractors would be eligible to submit proposals for these projects.
- The declaration of an exemption from competitive bidding must occur after public notice. The second reading and opportunity for public comment prior to enactment is scheduled to occur at the January 9, 2020 regular Board meeting.

Background:

The WWSP currently has six water transmission pipeline construction packages remaining for which it will lead the procurement. The current selection method is low bid to prequalified contractors. Under ORS 279C.300, construction contractors are selected through bidding low bid, open-competitive, or low bid with prequalification, unless an exemption is adopted by the LCRB. The WWSP is seeking approval from the LCRB for a class exemption to use a best value selection for certain construction projects that would enable consideration of total construction cost and non-cost factors such as technical approach and specialized expertise, from prequalified contractors.

Budget Impact:

There are no budgetary impacts anticipated from this item.

Page 2 of 2

December 5, 2019

Request to Local Contract Review Board for Exemption from
Competitive Bidding for Upcoming Water Transmission Pipeline Projects

Staff Contact Information:

David Kraska, P.E., WWSP Program Director; 503-941-4561; david.kraska@tvwd.org

Mike Britch, P.E., WWSP Engineering & Construction Manager; 503-941-4565; mike.britch@tvwd.org

Attachments:

1. Proposed Local Contract Review Board resolution
2. Exhibit 1 - Findings for an exemption from competitive bidding for a class of water transmission pipeline projects

RESOLUTION NO. WWSS-01-20

A RESOLUTION BY THE LOCAL CONTRACT REVIEW BOARD DECLARING AN EXEMPTION FROM COMPETITIVE BIDDING FOR CERTAIN WILLAMETTE WATER SUPPLY SYSTEM WATER TRANSMISSION PIPELINE PROJECTS AND APPROVING A BEST VALUE CONSTRUCTION CONTRACTOR SELECTION METHOD

WHEREAS, this matter came before the Board of Commissioners of the Willamette Water Supply System Commission (Commission), acting as the Local Contract Review Board for the Commission; and

WHEREAS, the Commission, formed by the Tualatin Valley Water District, the City of Hillsboro, and the City of Beaverton, has designated Tualatin Valley Water District as its Managing Agency to manage and deliver the Willamette Water Supply System (WWSS) which includes the class of water transmission pipeline projects; and

WHEREAS, the Managing Agency operates the Willamette Water Supply Program (WWSP) to construct the WWSS; and

WHEREAS, the WWSP staff evaluated the remaining water transmission pipeline projects for which WWSP will lead the procurement and determined which projects are best suited for a best value construction contractor selection method; and

WHEREAS, based on WWSP staff's evaluation, best value provides the greatest degree of owner control and enables selection of the best qualified construction contractor for a class of water transmission pipeline contracts consisting of PLM_4.3, PLW_1.3, and PLM_1.3; and

WHEREAS, the WWSP staff developed findings required by ORS 297C.335 for an exemption from competitive bidding for the class of projects, as described in Exhibit 1, attached hereto and incorporated by reference, concluding that the exemption is unlikely to encourage favoritism in the awarding of the contract or substantially diminish competition for the contract and that awarding a contract under the exemption will likely result in cost savings and other substantial benefits; and

WHEREAS, the Local Contract Review Board has noticed a public hearing on December 6, 2019 and conducted a public hearing on January 9, 2020 under ORS 297C.335 to provide opportunity for comments on the Findings as described in Exhibit 1, and being advised,

NOW, THEREFORE, BE IT RESOLVED BY THE BOARD OF COMMISSIONERS OF THE WILLAMETTE WATER SUPPLY SYSTEM COMMISSION, ACTING AS THE LOCAL CONTRACT REVIEW BOARD, THAT:

Section 1: The Commission hereby adopts the Findings attached as Exhibit 1 and grants the exemption from competitive bidding for this class of projects; and

Section 2: The Commission hereby directs and authorizes WWSP staff to take all action to adopt the best value construction contractor selection method for the class of projects.

Approved and adopted at a regular meeting held on the 9th day of January 2020.

James Duggan, Chair

Denny Doyle, Vice Chair

Willamette Water Supply System Commission

(this page intentionally left blank)

Exhibit 1 to Resolution No. WWSS-01-20**FINDINGS IN SUPPORT OF AN EXEMPTION FROM COMPETITIVE BIDDING****WILLAMETTE WATER SUPPLY SYSTEM****BEST VALUE FOR A CLASS OF WATER TRANSMISSION PIPELINE PROJECTS****I. GENERAL**

The Oregon Legislative Assembly encourages public agencies to consider alternative and innovative public improvement contracting methods that take into account other important considerations in addition to low bid. Under ORS 279C.335(2), a local contract review board may exempt certain public improvement contracts or classes of contracts from traditional low bid only competitive bidding by showing that an alternative contracting process is unlikely to encourage favoritism or diminish competition, and that it will result in cost savings and other substantial benefits to the public agency.

For the reasons set forth more fully below, it is recommended that contractors be selected by utilizing the competitive proposal process in accordance with ORS 279C.400 for a class of water transmission pipeline contracts consisting of PLM_4.3, PLW_1.3, and PLM_1.3. The competitive proposal process is advantageous for this class of projects as it allows for consideration of critical factors other than lowest bid price in selecting a contractor. It also allows contractors to customize their proposals to suggest creative and innovative approaches to project execution. The competitive proposal process also provides some degree of flexibility by allowing for negotiations with the contractor in order to obtain the best overall value for the Willamette Water Supply System Commission ("Owner").

II. BACKGROUND

Willamette Water Supply System Commission was formed to develop the Willamette Water Supply System ("WWSS") as a new water source through the work of the Willamette Water Supply Program ("WWSP"). The WWSS is a drinking water infrastructure project that will provide the Owner's members with a seismically resilient water supply to meet future demands and redundancy in case of an emergency event. The WWSS includes more than thirty (30) miles of transmission pipelines from the Willamette River Water Treatment Plant ("WRWTP") in Wilsonville, Oregon north to Tualatin Valley Water District, Hillsboro and Beaverton, Oregon. The WWSS also includes constructing finished water storage tanks (terminal storage), upgrades of the existing raw water facilities at the WRWTP, and a new water treatment plant.

The WWSP will lead the procurement of six construction packages to complete the WWSS. The current delivery method for those construction packages is low bid to prequalified contractors. Under ORS 279C.300, construction contractors are selected through bidding low bid, open-competitive, or low bid with prequalification, unless an exemption is adopted by the Local Contract Review Board ("LCRB").

Unlike the Competitive Bidding process typical to construction projects as defined by ORS 279C.300, selection employing a "best value" process may include other factors in addition to price. Procuring construction contractor services and awarding an agreement based on best value is permissible under ORS Chapter 279C and LCRB rules; however, the exemption process described in ORS 279C.335 must

be completed by the WWSP and approved by the LCRB prior to publishing a Request for Proposals (RFP) using the exempted process. The exemption process can be specific to a single contract or for a class of public improvement contracts (e.g., pipelines).

The remaining construction projects for which WWSP will lead the procurement, were evaluated to determine the recommended selection method. Of these six construction projects, three projects were selected, and have been grouped together here, for the purposes of a class exemption.

The recommended selection method for these projects is best value with prequalification. While prequalification assures firms have met minimum standards, some of these firms and their subcontractors may be better suited for each project, as further described below.

III. EVALUATION AND BASIS FOR SELECTION

Each of the six remaining WWSP-procured construction projects were evaluated for technical and logistical aspects that may benefit from consideration of bidding contractor's technical proposal and additional qualifications. This evaluation considered the following questions for project-specific elements:

- Public Benefits – Are there opportunities to propose a work approach that minimizes disruption and/or increases safety for businesses, residents, emergency services, and the traveling public?
- Schedule – Are there opportunities to propose advantageous alternate schedules?
- Value Engineering – Are there opportunities to offer significant value engineering proposals?
- Specialized Expertise – Does the project require specialized expertise beyond WWSP's minimum requirements for prequalification (e.g., substantial trenchless work)?
- Technical/planning complexity – Does the project's complexity warrant evaluation and comparison of each contractor's technical approach to executing the work (e.g., substantial trenchless work or traffic management)?

For the selected projects, evaluating the contractors' responses to technical and logistical aspects such as the trenchless subcontractor's qualifications, approach to managing groundwater contamination, and/or value engineering ideas are advantages provided by a best value approach. Some of the main drivers to utilize a best value selection for PLM_1.3 are that it would enable evaluation of a contractor's approach to crossing Wilsonville Road, including evaluation of traffic control and pipe installation methods that could prove beneficial to the schedule, traffic impacts, and local business impacts, and an evaluation of the contractor's approach to concrete road panel demolition and replacement. For PLM_4.3, a best value selection would enable an evaluation that includes a contractor's approach to trenchless crossings of the Tualatin River and Chicken Creek, including environmental and permit compliance approach, and an evaluation of tunneling contractors (not pre-qualified). For PLW_1.3, a best value selection would enable an evaluation that includes a contractor's approach to complex crossings of Butternut Creek (trenchless) and SW 209th Avenue (trenchless or open cut), and an evaluation of proposed tunneling contractors (not prequalified).

Using best value, contractors are evaluated on both price and qualitative criteria such as project team experience and performance, safety records, project personnel, and overall project approach.

Relative weighting of criteria would be tailored to the specific requirements of each project and published in the RFP.

For the other three WWSP-procured projects, it was determined that the design had not sufficiently advanced to understand the construction details. A decision on contractor selection method for the remaining construction projects has been deferred until design is advanced enough to evaluate whether or not a best value approach is recommended for those projects as well.

IV. LOCAL CONTRACT REVIEW BOARD (LCRB)

ORS 279C.335(1) requires, with certain exceptions, that all public contracts be based on competitive bidding and, under ORS 279C.375, be awarded to the lowest responsive and responsible bidder. ORS 279C.335(2) permits an exemption from this general requirement pending approval from a local contract review board. An exemption may be granted for a public improvement project or a class of public improvement contracts if the conditions described in ORS 279C.335(2) are met. The findings in this document demonstrate that those conditions are met and that the projects may be delivered through the “class special procurement” approach.

A class special procurement is a contracting procedure that allows for a Public Contract to be entered using alternative procurement methods rather than through a competitive bidding process.

This request is for approval to utilize a best value selection method for a class of construction projects.

To seek approval of a special procurement, a written request must be submitted to the WWSS Commission that describes the proposed contracting procedure and the circumstances that justify the use of a special procurement, whereby the special procurement is unlikely to encourage favoritism in the awarding of a public contract or substantially diminish competition. An exemption must also show that awarding the exemption will likely result in substantial cost savings or other substantial benefits. The following section presents WWSP staff findings relative to each of the factors required to be addressed by ORS 279C.335.

V. FINDINGS REGARDING COMPETITION

ORS 279C.335(2) requires that an agency make certain findings as a part of exempting certain public contracts or classes of public contracts from competitive bidding. ORS 279C.335(2)(a) requires an agency to find that: *“It is unlikely that such exemption will encourage favoritism in the awarding of public contracts or substantially diminish competition for public contracts.”*

Favoritism will not play a role in the selection of contractors. The selection will be based on a fair and unbiased process. Proposals will be evaluated based on clearly stated criteria that are not tailored to any specific contractor. A team of appointed WWSP, Tualatin Valley Water District, Hillsboro, and/or Beaverton staff will perform the evaluation. All qualified firms will be able to participate in the bidding.

Prequalified contractors will be selected through a competitive proposal process. No reduction in competition is expected since the proposed process is open to the same prequalified contractors as the current low bid method. WWSP recently solicited statements of qualification from interested contractors and updated its prequalified list to include a large pool of contractors, both local and national.

To mitigate the risk that prequalified contractors prefer the traditional low bid method and will not bid on a best value solicitation, WWSP will give public notice of the proposed LCRB exemption, conduct pre-bid outreach to contractors to promote awareness to the prequalified contractors, and emphasize the transparency in the selection process.

VI. FINDINGS REGARDING COST SAVINGS AND OTHER SUBSTANTIAL BENEFITS

ORS 279C.335(2) requires that a public agency make certain findings as part of exempting certain public contracts or classes of public contracts from competitive bidding. ORS 279C.335(2)(b) requires an agency to find that: “Awarding a public improvement contract under the exemption will likely result in substantial cost savings and other substantial benefits to the contracting agency or the state agency that seeks the exemption.”

In addition to the findings above, the selection of qualified contractors possessing the required experience and expertise is expected to result in overall cost savings to the Owner. Selecting the best contractor with an innovative approach to the project should optimize the construction and minimize challenges. WWSP has experience using the best value process for other contracts and has been able to achieve increased benefits and reduced risk from that process. Selecting the highest-scoring contractor should result in fewer change orders and claims. Selection considering the proposer’s key staff is expected to lead to more collaboration, which minimizes challenges and enables a focus on value engineering. Selecting the highest-scoring contractor provides the best overall value.

VII. FINDINGS REGARDING EXEMPTION FOR A CLASS OF PUBLIC IMPROVEMENT CONTRACTS

In making findings to support an exemption for a class of public improvement contracts, the contracting agency or state agency shall clearly identify the class using the class’s defining characteristics. The characteristics must include a combination of project descriptions or locations, time periods, contract values, methods of procurement or other factors that distinguish the limit and related class of public improvement contracts from the agency’s overall construction program.

PLM_4.3, PLW_1.3, and PLM_1.3 are all pipeline segments of the WWSS. The WWSS includes more than 30 miles of transmission pipelines, ranging from 48-inches to 66-inches in diameter from an intake at the Willamette River Water Treatment Plant (WRWTP) in Wilsonville, Oregon, north to Tualatin Valley Water District, Hillsboro, and Beaverton, Oregon.

VIII. CONCLUSION

In accordance with ORS Chapter 279C, an exemption from competitive bidding for a class of public improvement contracts and approval of a best value construction selection method will allow for the evaluation of contractors using price and technical factors with relative weighting of criteria tailored to the specific requirements. Using prequalified contractors, with experience best suited for each project based on specific criteria provides many benefits. The use of a competitive proposal process will not diminish competition or result in favoritism or increased cost. Additionally, this approach is expected to contribute to public benefit including minimized disruption to businesses, residents, emergency services, and traveling public.

Willamette Water Supply
Our Reliable Water

Recommendation for Use of Best Value Selection for Select Construction Contracts

December 5, 2019

1

Outline

- Recommendation preview
- Background
- Evaluation process
- Recommendation
- Implementation steps

Willamette Water Supply
Our Reliable Water

2

2

Recommendation Preview

Consider approving a motion to read by title only a draft resolution declaring an exemption from competitive bidding for a class of pipeline projects and approving the use of best value selection method for construction contractors, receive oral testimony or written comments and direct that the resolution be brought back for a second reading and adoption at the January 9, 2020 Board meeting.

3

Background

- Under ORS, Construction Contractors are selected through bidding
 - Low bid, open-competitive
 - Low bid, with prequalification
- WWSP uses low bid with prequalification
 - Prequalified pipeline contractors list
 - Prequalification basis: firm and key staff qualifications, safety record, bonding and financial capacity
- Use of best value selection for certain construction projects would enable consideration of
 - Total construction cost
 - Non-cost factors: technical approach and specialized expertise
 - From prequalified contractors
- Deciding now enables
 - Inclusion in the WWSP annual rebaseline plan (Dec. 2019 initial draft)
 - Application for the next anticipated contractor procurement (Feb. 2020)

4

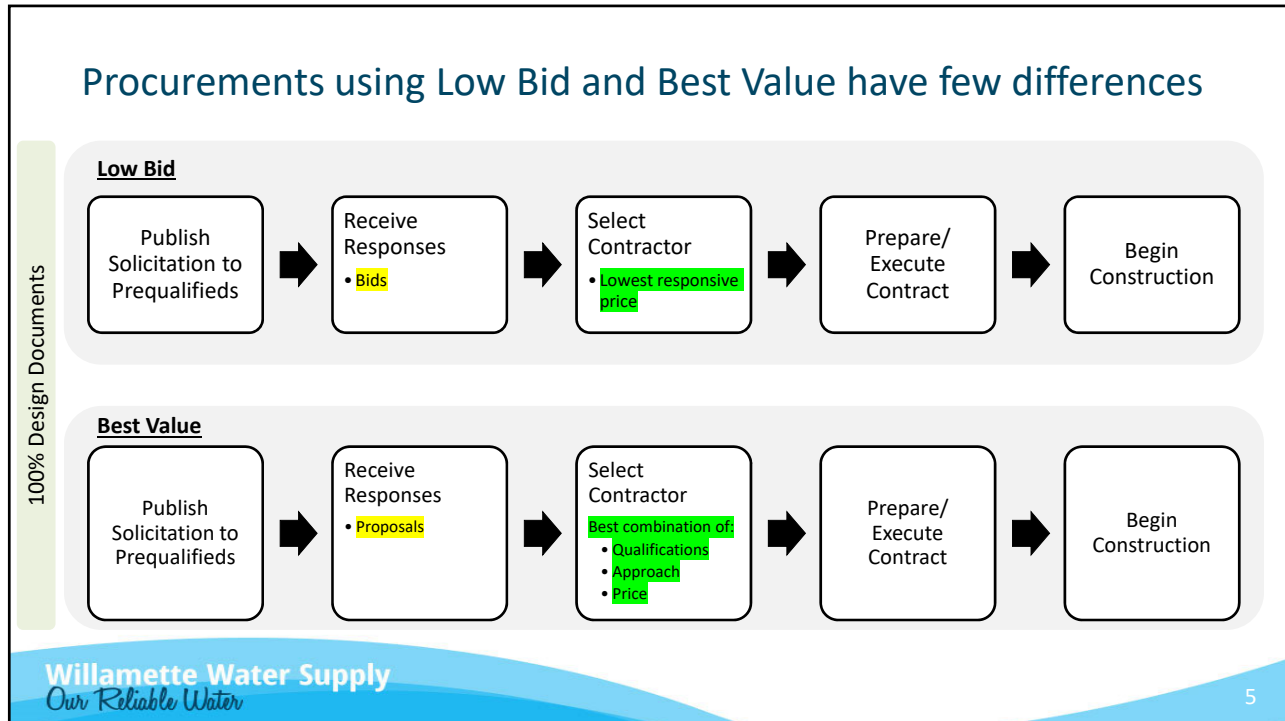

5

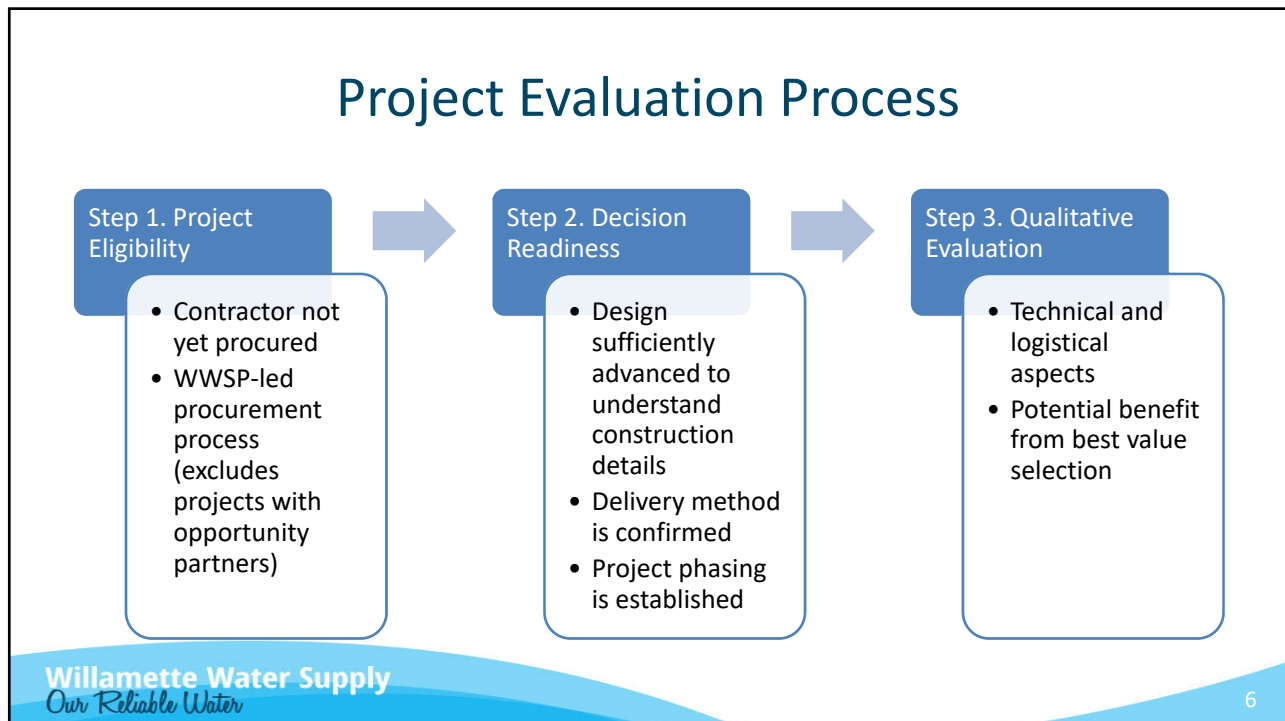

6

Step 1 Results – Eligible Projects

(Contractor not yet procured, WWSP-led procurement process)

Project	Description	Estimated Construction Value (\$ million)	Current Bid Date
PLM_1.3	2.2 miles 66-inch pipeline	\$32.4	Aug. 2020
PLM_4.3	2.5 miles 66-inch pipeline	\$60.3	Jun. 2021
RES_1.0/PLM_5.3	Two 15 MG tanks 3.8 miles 66-inch pipeline	\$142.3	Jun. 2021
PLW_1.3	1.2 miles 66-inch pipeline; 0.75 miles 30-inch pipeline	\$42.3	Feb. 2020
PLW_2.0	3.3 miles 48-inch pipeline	\$49.5	Feb. 2021
MPE_1.0	7.3 miles 48-inch pipeline	\$90.9	Jan. 2021

Willamette Water Supply
Our Reliable Water

7

Step 2 Results – Project Readiness

Project	Design Sufficiently Advanced to Understand Construction Details	Delivery Method is Confirmed	Project Phasing is Established
✓ PLM_1.3	Yes 30% design	Yes Design-Bid-Build	Yes Single phase
✓ PLM_4.3	Yes 90% design	Yes Design-Bid-Build	Yes Single phase
✗ RES_1.0/PLM_5.3	No RES_1.0 design in procurement PLM_5.3 30% design	No Evaluation in early 2020	No Evaluation in early 2020
✓ PLW_1.3	Yes 90% design	Yes Design-Bid-Build	Yes Single phase
✗ PLW_2.0	No 30% design	Yes Design-Bid-Build	No Evaluation in progress
✗ MPE_1.0	No 30% design	Yes Design-Bid-Build	No Evaluation in progress

Willamette Water Supply
Our Reliable Water

8

8

Step 3. Project Evaluation

Each project advancing from Step 2 was evaluated for technical and logistical aspects that may benefit from consideration of bidding contractor's technical proposal and additional qualifications

- **Public Disruption/Safety**
 - There are opportunities to propose a work approach that minimizes disruption and/or increases safety for businesses, residents, emergency services, and traveling public
- **Schedule**
 - There are opportunities to propose advantageous alternative schedules
- **Value Engineering**
 - There are opportunities to offer significant value engineering proposals
- **Specialized Expertise**
 - The project requires specialized expertise beyond WWSP's minimum requirements for prequalification (e.g., substantial trenchless work)
- **Technical/Planning Complexity**
 - The project's complexity warrants evaluation and comparison of each contractor's technical approach to executing the work (e.g., substantial trenchless work or traffic management)

PLM_1.3

Best value selection would enable evaluation of:

- **Contractor's approach to crossing Wilsonville Road**
 - Traffic control
 - Open cut or trenchless methods
- **Trenchless subcontractor's qualifications (firm and personnel)**
 - Up to two trenchless crossings
- **Contractor's approach to managing groundwater contamination**
- **Contractor's overall approach to traffic control**

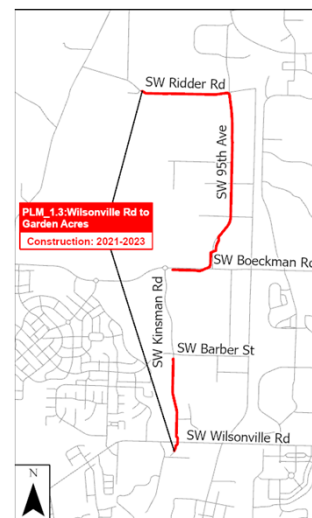

PLM_4.3

Best value selection would enable evaluation of:

- Contractor's approach to trenchless crossings
 - Tualatin River
 - Chicken Creek
- Trenchless subcontractor's qualifications (firm and personnel)
- Contractor's approach to managing Federal stakeholder coordination

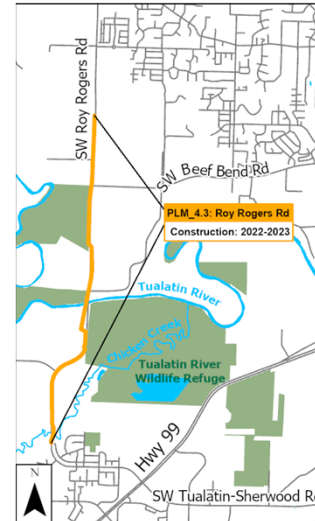

PLW_1.3

Best value selection would enable evaluation of:

- Contractor's approach to complex crossings
 - Butternut Creek (trenchless)
 - SW 209th Ave (open cut)
- Trenchless subcontractor's qualifications (firm and personnel)

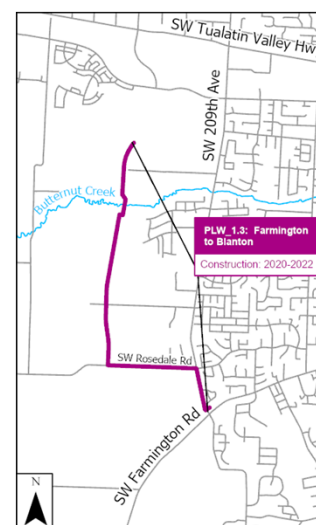

Best Value Evaluation Criteria

- The following types of criteria would be used for best value evaluations:
 - Qualitative
 - Project Team Experience and Performance
 - Project Personnel
 - Project Approach
 - Price Proposal
- Relative weighting of criteria would be tailored to the specific requirements of each project and published in the RFP

Notable Risks of Using Best Value Selection

- Additional level of effort for bidders
 - Mitigation: Limit length and complexity of proposals
- Increased potential for protest
 - Mitigation: Public notice of proposed LCRB exemption
 - Mitigation: Pre-bid outreach to contractors to promote awareness
- Potential for higher initial construction contract pricing
 - Mitigation: Apply a high relative weight to price
 - Opportunity: May result in fewer change orders/claims

Exemption Summary

The use of best value selection for construction contractors for PLM_1.3, PLM_4.3, and PLW_1.3:

- Is unlikely to encourage favoritism or reduce competition
- Will likely result in cost savings and other substantial benefits

Recommendation

Consider approving a motion to read by title only a draft resolution declaring an exemption from competitive bidding for a class of pipeline projects and approving the use of best value selection method for construction contractors, receive oral testimony or written comments and direct that the resolution be brought back for a second reading and adoption at the January 9, 2020 Board meeting.

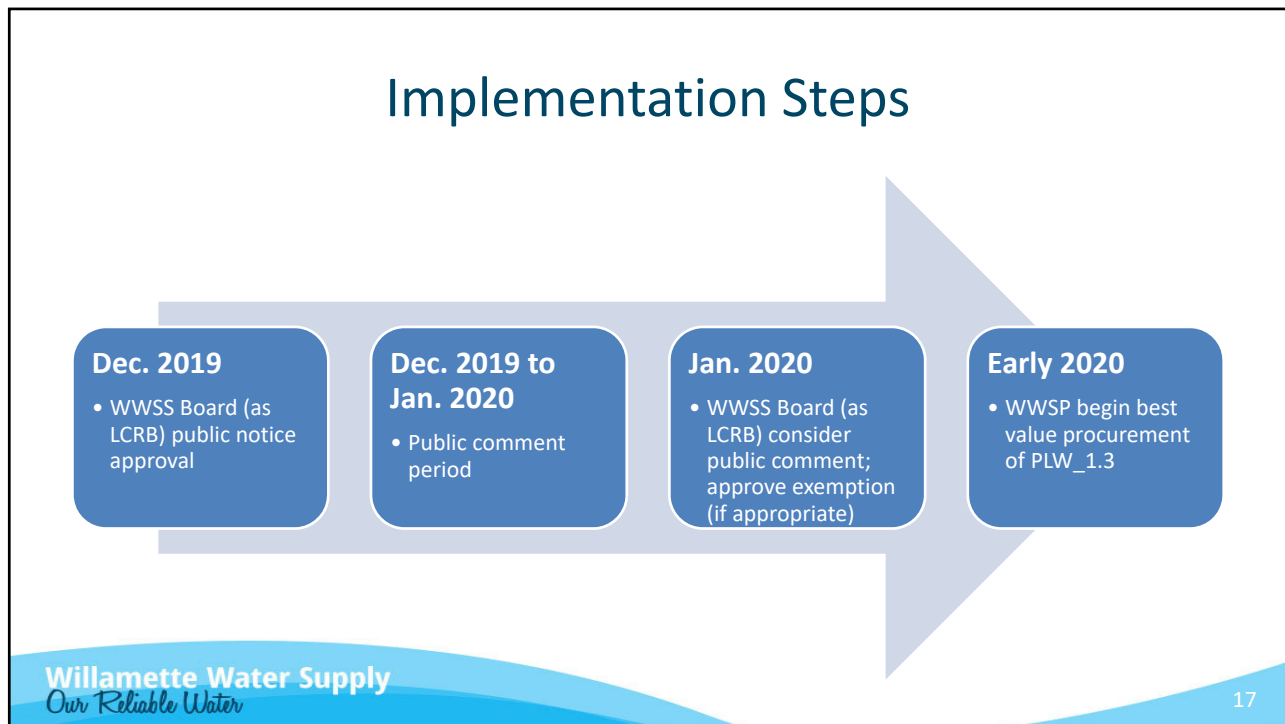

17

QUESTIONS

Willamette Water Supply
Our Reliable Water

18

18

Willamette Water Supply System Commission

(this page intentionally left blank)

STAFF REPORT

To: Willamette Water Supply System Board of Commissioners
From: David Kraska, P.E., Willamette Water Supply System General Manager
Date: December 5, 2019
Subject: Anticipated Business Agenda Items for the January 9, 2020 Meeting of the Willamette Water Supply System Board of Commissioners

Key Concepts:

- The January WWSS Commission Board meeting agenda is anticipated to include a contract amendment for permitting services as well as actions for the Local Contracting Review Board.

Background:

Staff have been working with David Evans and Associates, Inc. (DEA) to develop a contract amendment for Program Regulatory Permitting and Related Consulting Services and will recommend that the Board approves the amendment in January. The original contract was executed in October 2015 and its current value is \$5,301,154. This amendment will extend the duration of services to February 2021 and provide additional permitting assistance. The amendment includes supporting efforts from DEA and several subconsultants in the areas of: land use permitting, hazardous materials assessments, historical and cultural resource assessments, and finalization of the thermal trading plan (a requirement of the issued Department of Environmental Quality/Clean Water Act Section 401 certification).

The amendment value is expected to exceed the Program Director's authority limit for approval. The overall contract expires in 2027.

Also in January, staff will recommend that the WWSS Board, acting as the Local Contracting Review Board (LCRB), adopt resolutions that allow for the exemption from competitive bidding per ORS 279C.300. Under ORS 279C.300, construction contractors are selected through bidding low-bid, open-competitive or low bid with prequalifications methods unless an exemption is adopted by the LCRB.

The resolution would allow for the use of a best value method of selection of prequalified pipeline contractors for PLM_1.3, PLM_4.3, and PLW_1.3

Findings documents will be prepared to justify this exemption from competitive bidding. A 30-day public notice period is required to allow for public comment on the findings at the January 9, 2020 Board meeting.

Budget Impact:

No budgetary impact. The funds for these efforts are included in the WWSP Baseline budget.

Staff Contact Information:

Dave Kraska, WWSP Program Director, 503-941-4561, david.kraska@tvwd.org
Clark Balfour, General Counsel, 503-848-3061, clark.balfour@tvwd.org

Page 2 of 2

December 5, 2019

Anticipated Business Agenda Items for the January 9, 2020 Meeting of the Willamette Water Supply System Board of Commissioners

Attachments:

None.